

YAMAHA

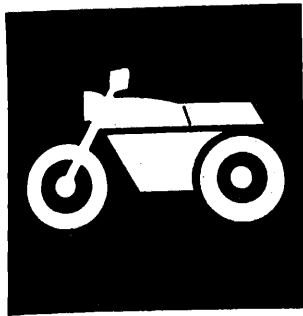

**PARTS
CATALOGUE**

XV535'93 (3BTR/3BTT) (FLAT)

XV535'93 (3BTP/3BTS) (UP) EUROPE

133BT-300E1

YAMAHA
GENUINE
Parts & Accessories

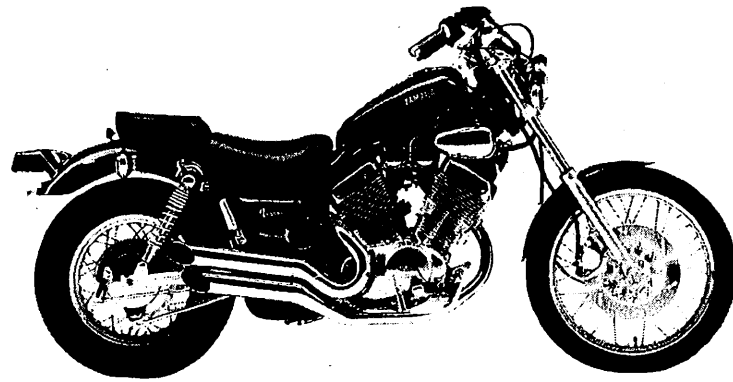

A3



FOREWORD

This Parts Catalogue is related to the parts in use for the Yamaha XV535'93(3BTR/3BTT), XV535'93(3BTP/3BTS). When you are ordering replacement parts for the XV535'93(3BTR/3BTT), XV535'93(3BTP/3BTS), refer to this Parts Catalogue and quote both part numbers and part names correctly.

1. Modifications or additions which have been made after issue of the Parts Catalogue will be announced in the Yamaha Parts News.

It is advisable that according to the Yamaha Parts News you make necessary corrections to the Parts Catalogue on hand to keep it up-to-date.

2. Abbreviations

The following abbreviations are used in this Parts Catalogue.

- U.R. Use size (thickness) and/or number as required.
- U.N. Use as many as you need.
- A.P. Alternate Parts
- L.M. Local Made
- F# Frame No. (Applicable machine No.)

3. The parts marked with (*) in the parts number column of this Catalogue are not supplied with by Yamaha, those have to be found locally.

4. Parts, which are to be supplied in the form of assemblies, are listed with an indentation of one letter's space, and a dot (.) is put against the name of each part.

EXAMPLE CARBURETOR ASS'Y
 . JET, pilot
 . NOZZLE, main

5. Indication of No. of constituent parts for assembly

The numeral appearing to the right of each constituent part under the description indicates the quantity of such parts for each individual assembly unit.

EXAMPLE

Part No.	Description	Q'ty	Remarks
2F5-83310-60	FRONT FLASHER LIGHT ASS'Y	2	
115-83311-60	. BULB (6V-18W)	1	
1M1-83309-60	. REFLECTOR	1	

6. Initial Serial No. and Color Code

3BTR	(A) Frame Serial No.	2YL-098101 and following
	(B) Engine Serial No.	2YL-098101 and following
3BTT	(A) Frame Serial No.	2YL-113101 and following
	(B) Engine Serial No.	2YL-113101 and following
3BTP	(A) Frame Serial No.	2YL-093101 and following
	(B) Engine Serial No.	2YL-093101 and following
3BTS	(A) Frame Serial No.	2YL-109101 and following
	(B) Engine Serial No.	2YL-109101 and following

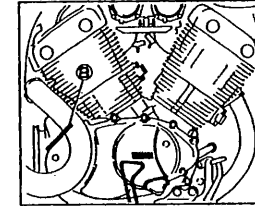
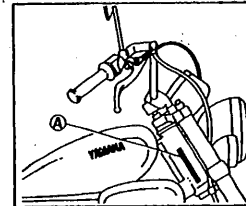

Color Code	Color Name	Abbreviate
0175	LIGHT GRAYISH BLUE METALLIC 1	LGBM1
00R0	GRACEFUL MAROON	GRM
004B	BLACK 2	BL2

7. Applicable colors of graphics are represented in the "Remarks" column by the letter(s) appropriately picked out of the full word(s) showing such colors.

EXAMPLE

Part No.	Description	Q'ty	Remarks
2N4-24110-00-X5	FUEL TANK COMP.	1	MAXIM RED
3J1-24240-10	. GRAPHIC, fuel tank set	1	for MXR

CONTENTS

GENERAL SPEC.

ENGINE

Cylinder Head	B2 ~ B3
Cylinder	B4
Crankshaft, Piston	B5
Valve	B6
Camshaft, Chain	B7
Oil Pump	B8
Oil Cleaner	B9
Intake	B10
Carburetor	B11 ~ B12
Exhaust	B13
Crankcase	B14 ~ B15
Crankcase Cover 1	C2 ~ C3
Starter Clutch	C4
Clutch	C5 ~ C6
Transmission	C7
Middle Drive Gear	C8
Shift Cam, Fork	C9
Shift Shaft	C10

CHASSIS

Frame	C11 ~ C12
Fender	C13 ~ C14
Side Cove	C15 ~ D2
Rear Arm. Suspension	D3
Drive Shaft	D4 ~ D5
Steering	D6 ~ D7
Front Fork	D8 ~ D9
Fuel Tank	D10 ~ D12
Seat	D13

Front Wheel	D14
Front Brake Caliper	D15
Rear Wheel	E2 ~ E3
Steering Handle, Cable (Flat)	E4
Steering Handle, Cable (Up)	E5
Front Master Cylinder (Flat)	E6
Front Master Cylinder (Up)	E7
Stand, Footrest	E8 ~ E10
Generator	E11
Starting Motor	E12
Flasher Light	E13
Meter	E14
Headlight	E15
Taillight	F2
Handle Switch, Lever (Flat)	F3
Handle Switch, Lever (Up)	F4
Electrical 1	F5
Electrical 2	F6

INDEX (GENERAL SPEC.)

Numerical Index	L2 ~ L5
-----------------------	---------

INDIVIDUAL SPEC. FOR ITALY HOLLAND GREECE

Alternate (Chassis)	F8
Alternate (Headlight)	F9
Alternate (Taillight)	F10

FOR SWEDEN FINLAND NORWAY

Alternate (Chassis)	F12
Alternate (Meter)	F13
Alternate (Headlight)	F14

INDEX (INDIVIDUAL SPEC.)

Numerical Index	M2
-----------------------	----

GENERAL SPEC.



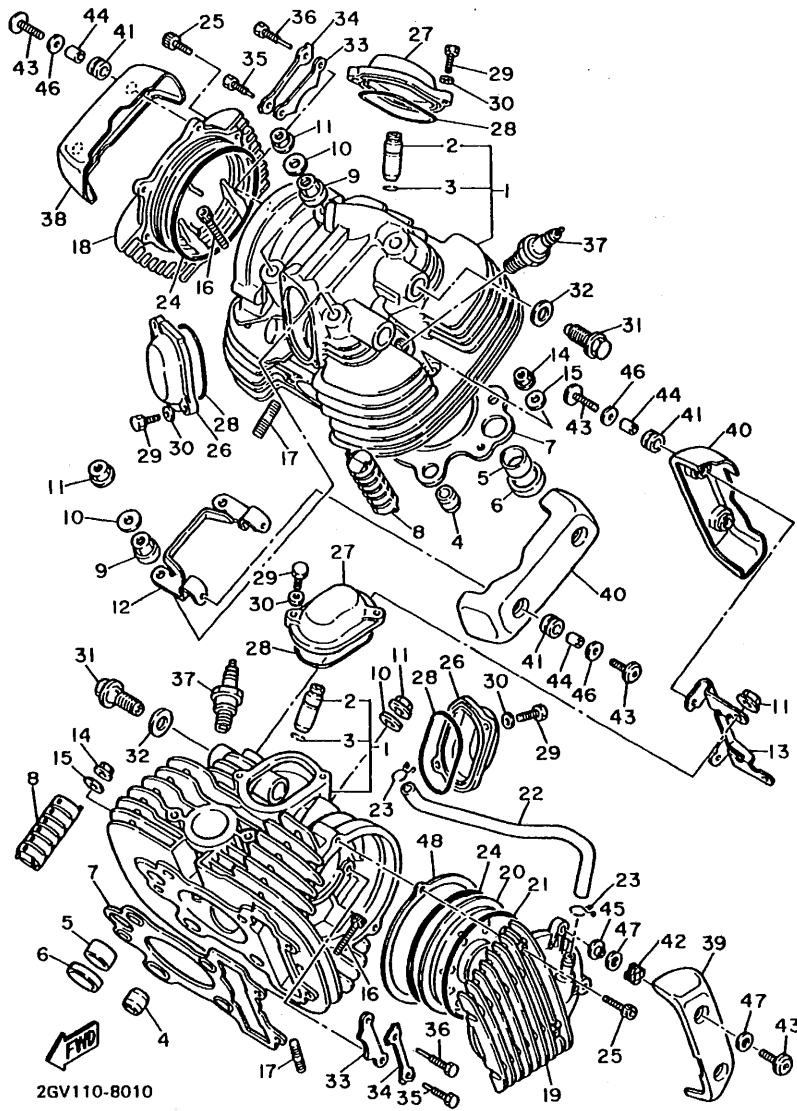
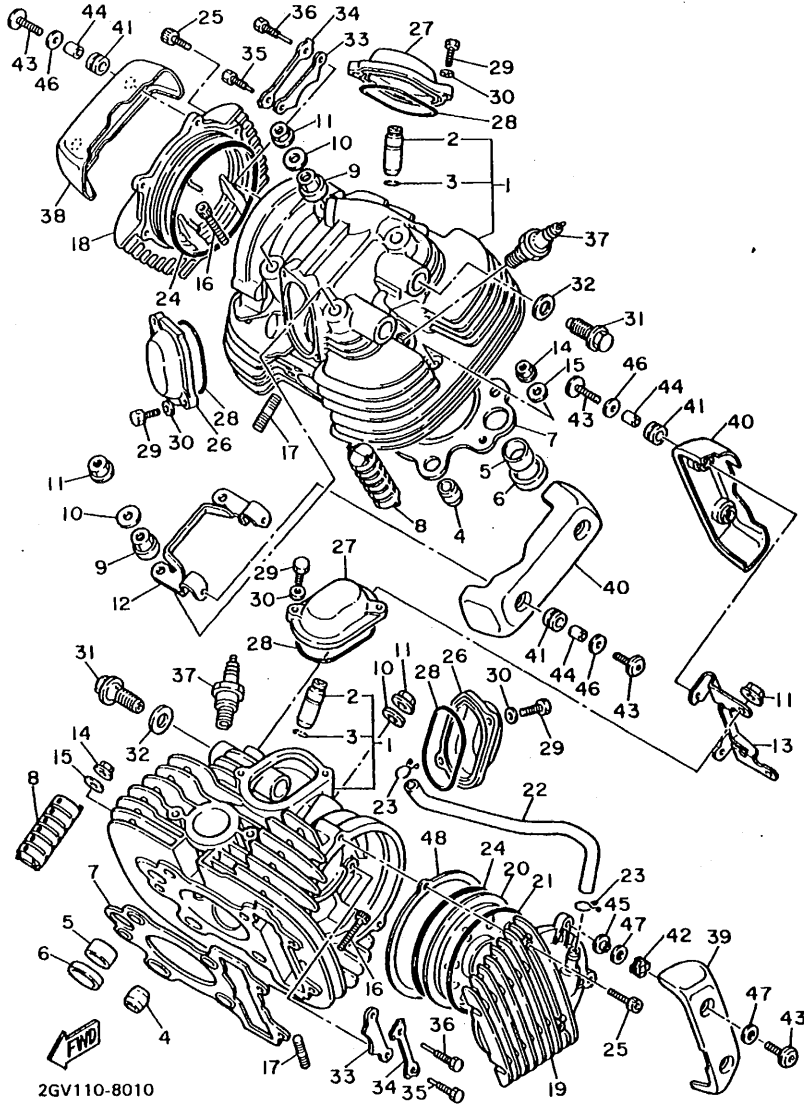

FIG. 1 CYLINDER HEAD

REF. NO.	PART NO.	DESCRIPTION	Q'TY	REMARKS
1	2GV-11102-00	CYLINDER HEAD ASSY	2	
2	4H7-11133-10	.GUIDE, intake valve	2	
3	93440-12052	.CIRCLIP	2	
4	99510-17016	PIN, dowel	4	
5	90387-22667	COLLAR	2	
6	90430-24184	GASKET	2	
7	2GV-11181-00	GASKET, cylinder head 1	2	
8	2GV-11127-00	ABSORBER 3	4	
9	90179-10395	NUT	4	
10	90201-10131	WASHER, plate	8	
11	90179-10279	NUT	8	
12	2GV-11142-00	BRACKET, cylinder head cover 2	1	
13	2GV-11152-00	BRACKET, cylinder head cover	1	
14	95701-08500	NUT, flange	2	
15	90201-094G1	WASHER, plate	2	
16	91311-08030	BOLT	4	
17	95611-08630	BOLT, stud	4	
18	2GV-11185-00	COVER, cylinder head side 1	1	
19	2GV-1111H-00	COVER, cylinder head side 4	1	
20	22U-11165-00	PLATE, breather	1	
21	93210-89568	O-RING	1	
22	2GV-11166-00	PIPE, breather 1	1	
23	90467-14015	CLIP	2	
24	93211-00612	O-RING	2	
25	91311-06025	BOLT	4	
26	22U-11186-00	COVER, cylinder head side 2	2	
27	22U-11187-00	COVER, cylinder head side 3	2	
28	93210-62446	O-RING	4	

FIG. 1 CYLINDER HEAD



REF. NO.	PART NO.	DESCRIPTION	Q'TY	REMARKS
29	97021-06016	BOLT	8	
30	92901-06600	WASHER, plate	8	
31	90401-16073	BOLT, union	4	
32	90430-17168	GASKET	4	
33	22U-1111F-01	PLATE	2	
34	90215-08229	WASHER, lock	2	
35	90109-08782	BOLT	2	
36	90109-08781	BOLT	2	
37	94701-00218	PLUG, spark (NGK BPR7ES)	2	UR
	94701-00220	PLUG, spark (ND W22EPR-U)	2	UR
38	2NT-11186-00	COVER, cylinder head side 2	1	
39	2NT-1110M-00	COVER ASSY 1	1	
40	2NT-11187-00	COVER, cylinder head side 3	2	
41	90480-18411	GROMMET	6	
42	90480-19471	GROMMET	2	
43	90110-06198	BOLT, hexagon socket head	8	
44	90387-06518	COLLAR	6	
45	90387-072W2	COLLAR	2	
46	90201-06697	WASHER, plate	6	
47	3BT-11195-00	WASHER, plate	4	
48	3BT-11196-00	GASKET, cylinder head side	1	

2GV110-8010

B3

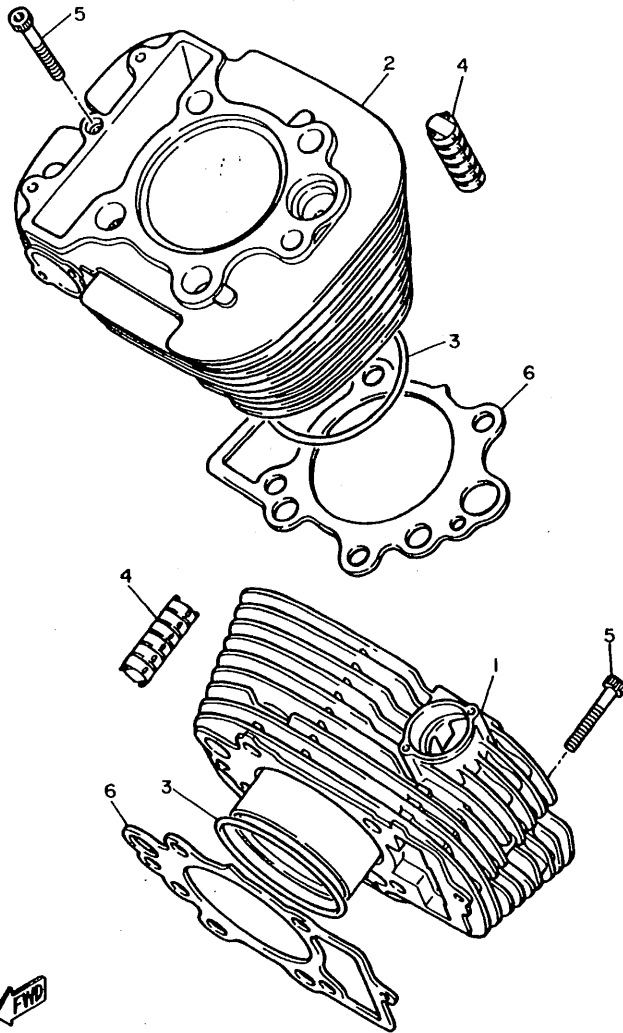

FIG. 2 CYLINDER

REF. NO.	PART NO.	DESCRIPTION	Q'TY	REMARKS
1	2GV-11310-00	CYLINDER	1	
2	2GV-11320-00	CYLINDER 2	1	
3	93210-81411	O-RING	2	
4	15A-11162-00	ABSORBER 2	6	
5	91311-06085	BOLT	2	
6	3BT-11351-00	GASKET, cylinder	2	



2GV110-7020

B4

FIG. 3 CRANKSHAFT. PISTON

REF. NO.	PART NO.	DESCRIPTION	Q'TY	REMARKS
1	22U-11411-00	CRANKSHAFT	1	
2	2GV-11631-00	PISTON (STD)	2	
	2GV-11636-00	PISTON (0.50MM O/S)	2	AP
	2GV-11638-00	PISTON (1.00MM O/S)	2	AP
3	2GV-11610-00	PISTON RING SET (STD)	2	
	2GV-11610-20	PISTON RING SET (0.50MM O/S)	2	AP
	2GV-11610-40	PISTON RING SET (1.00MM O/S)	2	AP
4	22U-11633-01	PIN, piston	2	
5	93450-19052	CIRCLIP	4	
6	22U-11650-00	CONNECTING ROD ASSY	2	
7	22U-11654-00	.BOLT, connecting rod	2	
8	90179-08327	.NUT	2	
9	22U-11656-00	PLANE BEARING, connecting rod	4	UR BLUE
	22U-11656-10	PLANE BEARING, connecting rod	4	UR BLACK
	22U-11656-20	PLANE BEARING, connecting rod	4	UR BROWN
	22U-11656-30	PLANE BEARING, connecting rod	4	UR GREEN
10	90280-05048	KEY, woodruff	1	

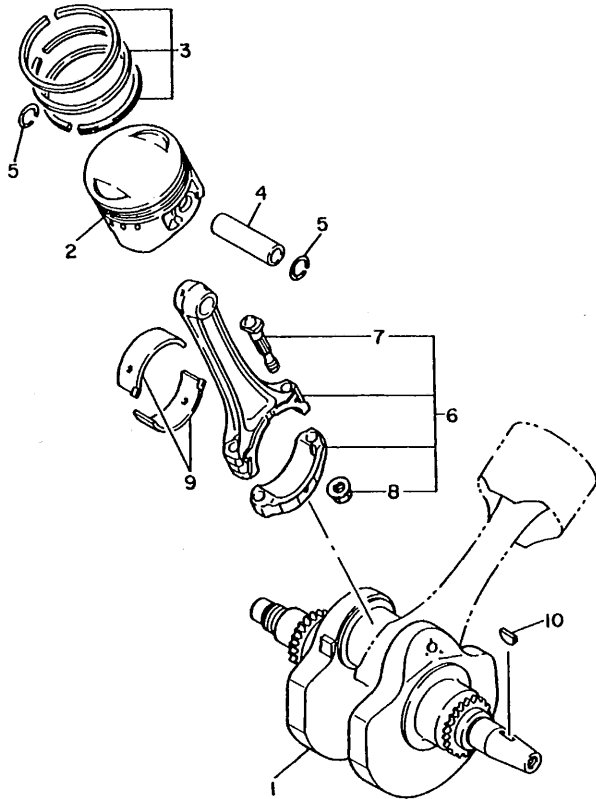

2GV110-7030

B5

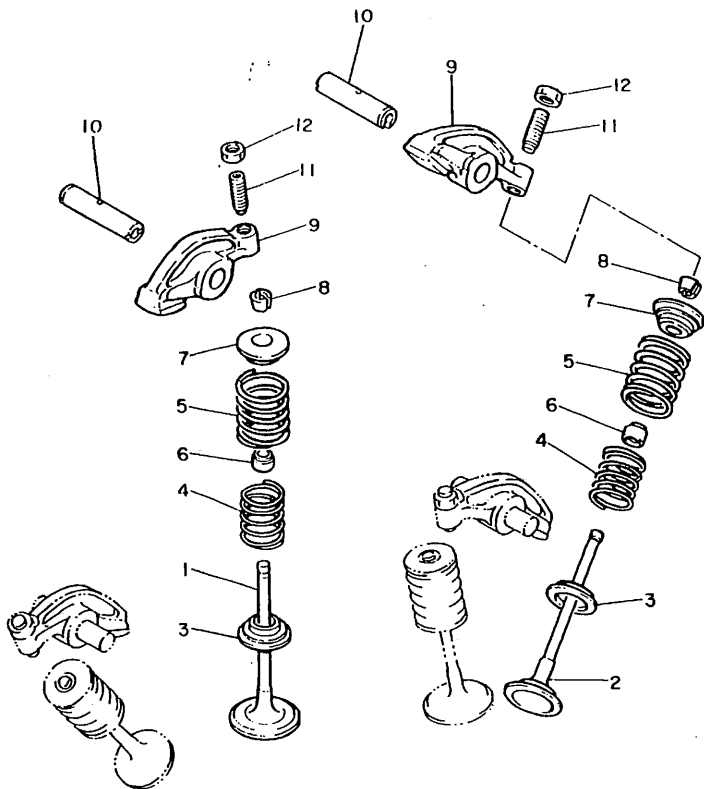

FIG. 4 VALVE

REF. NO.	PART NO.	DESCRIPTION	Q'TY	REMARKS
1	22U-12111-00	VALVE, intake	2	
2	22U-12121-01	VALVE, exhaust	2	
3	3Y1-12116-00	SEAT, valve spring	4	
4	22U-12113-00	SPRING, valve inner	4	
5	22U-12114-00	SPRING, valve outer	4	
6	1J7-12119-01	SEAL, valve stem	4	
7	3Y1-12117-01	RETAINER, valve spring	4	
8	1J7-12118-00	COTTER, valve	8	
9	22U-12151-00	ARM, valve rocker	4	
10	22U-12156-01	SHAFT, rocker 2	4	
11	22U-12159-00	SCREW, valve adjusting	4	
12	90170-06128	NUT	4	



22U110-3050

B6

FIG. 5 CAMSHAFT. CHAIN

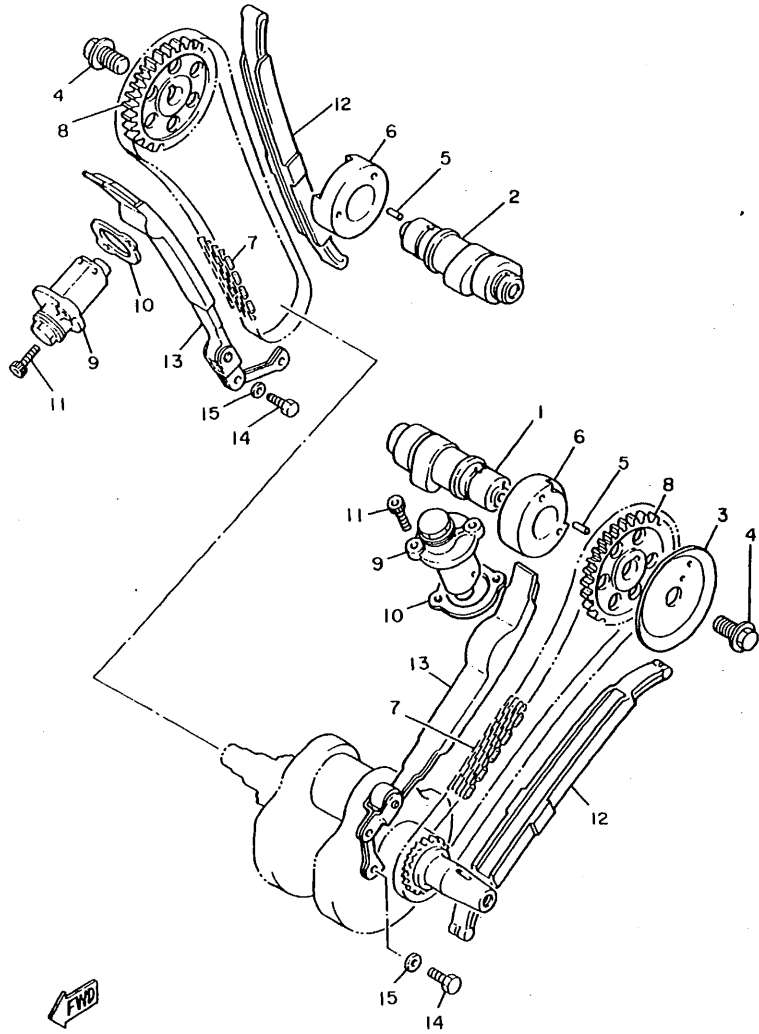

REF. NO.	PART NO.	DESCRIPTION	Q'TY	REMARKS
1	22U-12171-01	CAMSHAFT 1	1	
2	22U-12181-01	CAMSHAFT 2	1	
3	22U-11145-00	PLATE, breather 2	1	
4	90105-10217	BOLT, washer based	2	
5	93605-10108	PIN, dowel	2	
6	90380-28110	BUSH, solid	2	
7	94590-27118	CHAIN	2	
8	22U-12176-01	SPROCKET, cam chain	2	
9	11H-12210-01	TENSIONER ASSY, cam chain	2	
10	3BT-12213-00	GASKET, tensioner case	2	
11	91311-06025	BOLT	4	
12	22U-12231-00	GUIDE, stopper 1	2	
13	22U-12241-00	GUIDE, stopper 2	2	
14	97021-06016	BOLT	4	
15	92901-06600	WASHER, plate	4	

FWD
22U110-3040

B7

FIG. 6 OIL PUMP

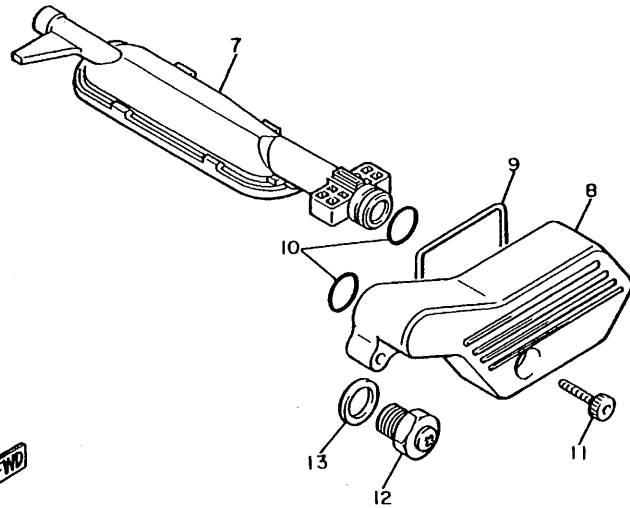
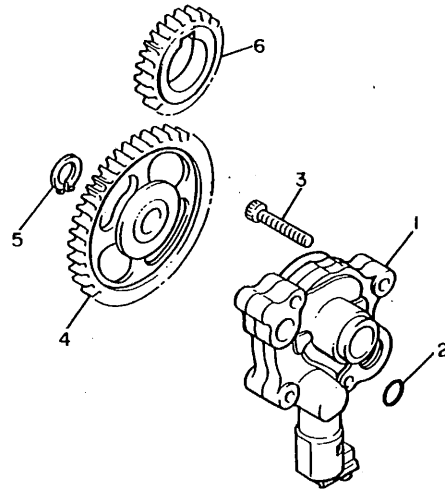

2GV110-7060

REF. NO.	PART NO.	DESCRIPTION	Q'TY	REMARKS
1	22U-13300-00	OIL PUMP ASSY	1	
2	93210-10096	O-RING	1	
3	91311-06030	BOLT	3	
4	22U-13325-00	GEAR, driven (39T)	1	
5	99009-11400	CIRCLIP	1	
6	22U-13324-00	GEAR, drive (24T)	1	
7	22U-13410-00	STRAINER HOUSING ASSY	1	
8	2GV-13417-00	COVER, strainer	1	
9	22U-13415-00	SEAL, oil strainer	1	
10	93210-15151	O-RING	2	
11	91311-06025	BOLT	3	
12	11H-13455-00	PLUG	1	
13	214-11198-01	GASKET	1	

B8

FIG. 7 OIL CLEANER

REF. NO.	PART NO.	DESCRIPTION	Q'TY	REMARKS
1	4X7-13440-90	ELEMENT ASSY, oil cleaner	1	
2	2NT-13447-00	COVER, oil element	1	
3	93210-64297	O-RING	1	
4	91311-06060	BOLT	1	
5	91311-06095	BOLT	1	
6	91311-06025	BOLT	1	

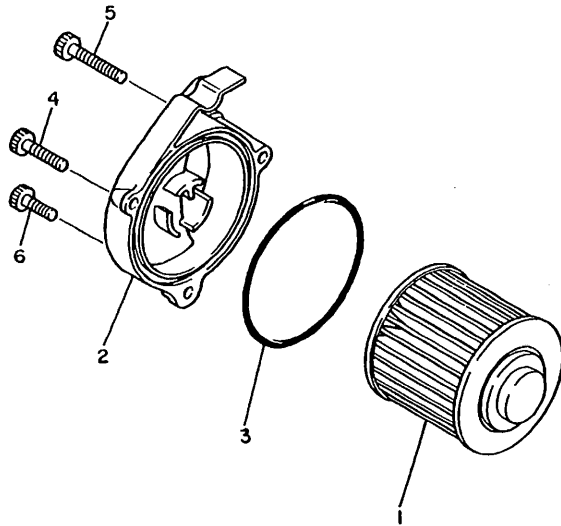

2GV110-7070

B9

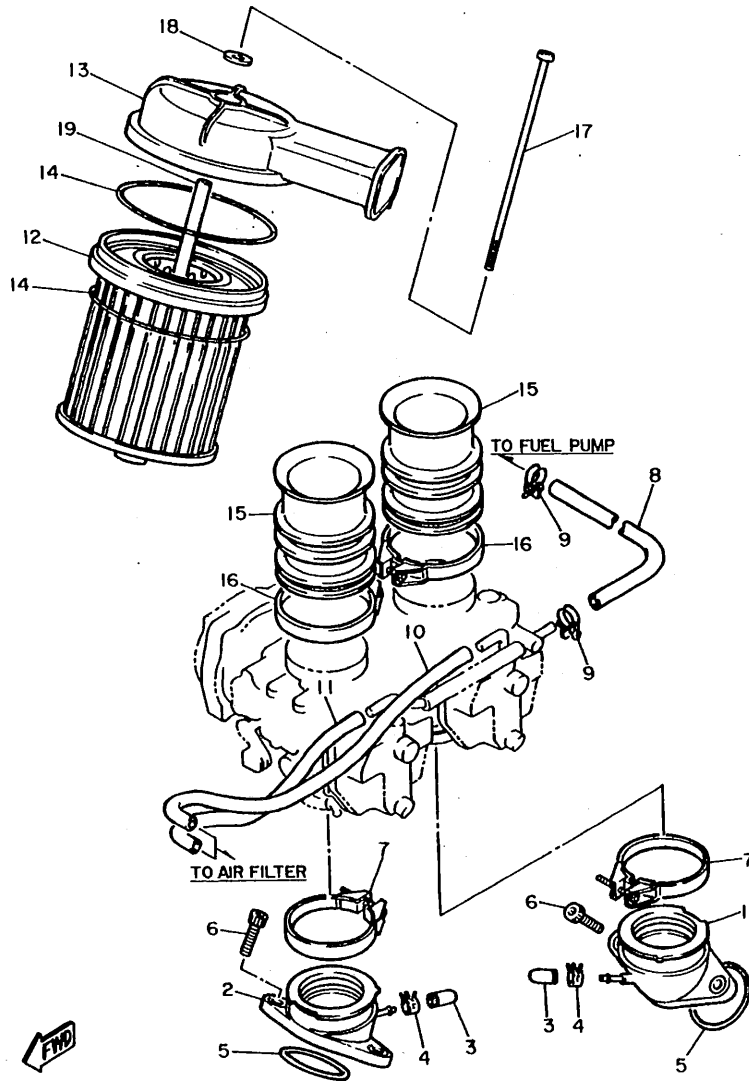

FIG. 8 INTAKE

REF. NO.	PART NO.	DESCRIPTION	Q'TY	REMARKS
1	2GV-13586-00	JOINT, carburetor 1	1	
2	2GV-13596-00	JOINT, carburetor 2	1	
3	16G-13569-00	PLUG, blind	2	
4	90467-10039	CLIP	2	
5	93210-36549	O-RING	2	
6	91316-06020	BOLT	4	
7	90460-52264	CLAMP, hose	2	
8	90445-111F3	HOSE	1	
9	90460-12256	CLAMP, hose	2	
10	2GV-14197-00	PIPE	1	
11	2GV-14987-00	HOSE	1	
12	2GV-14451-00	ELEMENT, air cleaner	1	
13	2GV-14412-00	CAP, cleaner case 1	1	
14	52W-14452-00	SEAL	2	
15	22U-14469-00	FUNNEL, air	2	
16	90460-58015	CLAMP, hose	2	
17	98511-06160	SCREW, pan head	1	
18	90201-06067	WASHER, plate	1	
19	90387-062T3	COLLAR	1	



2GV110-7080

B10

FIG. 9 CARBURETOR

REF. NO.	PART NO.	DESCRIPTION	Q'TY	REMARKS
1	3BT-14900-01	CARBURETOR ASSY	1	
2	3BT-14901-01	..CARBURETOR ASSY 1	1 (# 1)	
3	3BT-14902-01	..CARBURETOR ASSY 2	1 (# 2)	
4	1FK-14933-00	..SPRING, diaphragm	1	
5	3G2-14231-34	..JET, pilot air (#170)	1	
6	22U-1490H-00	..DIAPHRAGM SET, 5	1	
7	41R-14940-00	..DIAPHRAGM ASSY	1	
8	2JV-1490J-00	..NEEDLE SET	1 (# 1)	
	2JV-1490J-10	..NEEDLE SET	1 (# 2)	
9	11H-1410A-00	..STARTER SET	1	
10	22U-14536-00	..GASKET	1	
11	22U-14565-00	..SCREW	1	
12	137-14153-00	..WASHER, main jet	1	
13	2JU-14141-90	..NOZZLE, main	1	
14	22U-14147-00	..O-RING	1	
15	98506-04018	..SCREW, pan head	1	
16	92902-04100	..WASHER, spring	1	
17	3G2-14231-14	..JET, pilot air (#70)	1	
18	1FK-14190-15	..NEEDLE VALVE ASSY	1	
19	3JB-14985-00	..FLOAT	1	
20	4G0-14142-35-A0	..JET, pilot (#35)	1	
21	98511-04012	..SCREW, pan head	4	
22	92901-04100	..WASHER, spring	4	
23	22U-14968-00	..CAP	1	
24	22V-14968-00	..CAP	1	
25	98501-05016	..SCREW, pan head.	3	
26	98580-04010	..SCREW, pan head	3	
27	92901-04100	..WASHER, spring	3	

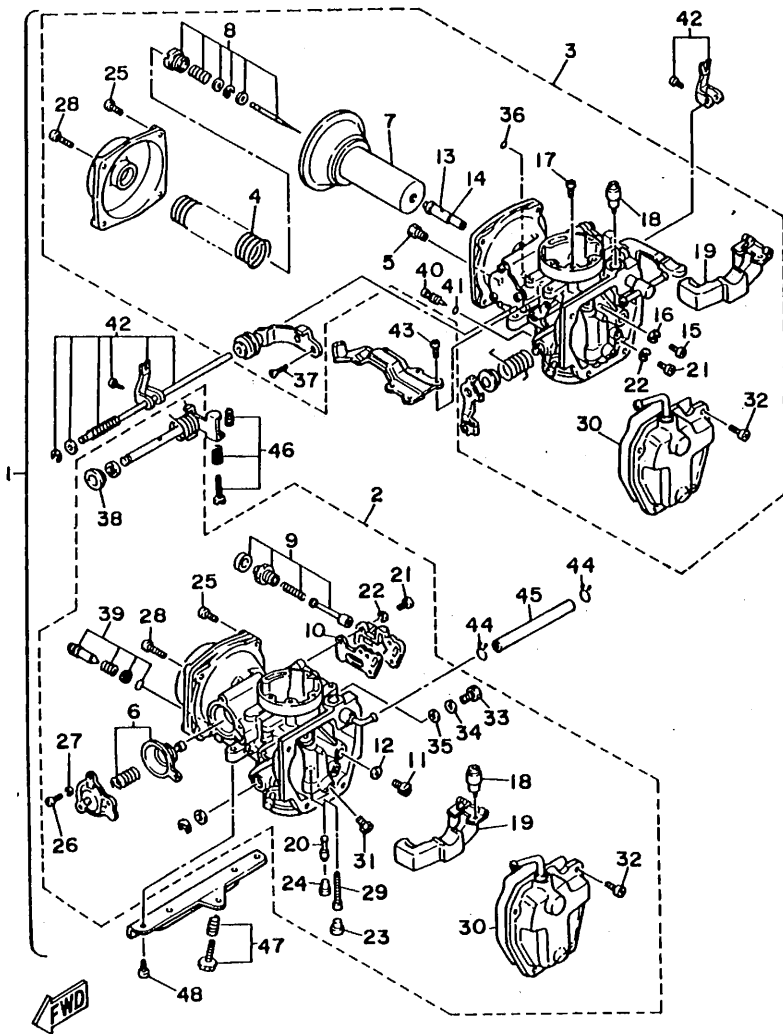

3BT8332-0090

B11

FIG. 9 CARBURETOR

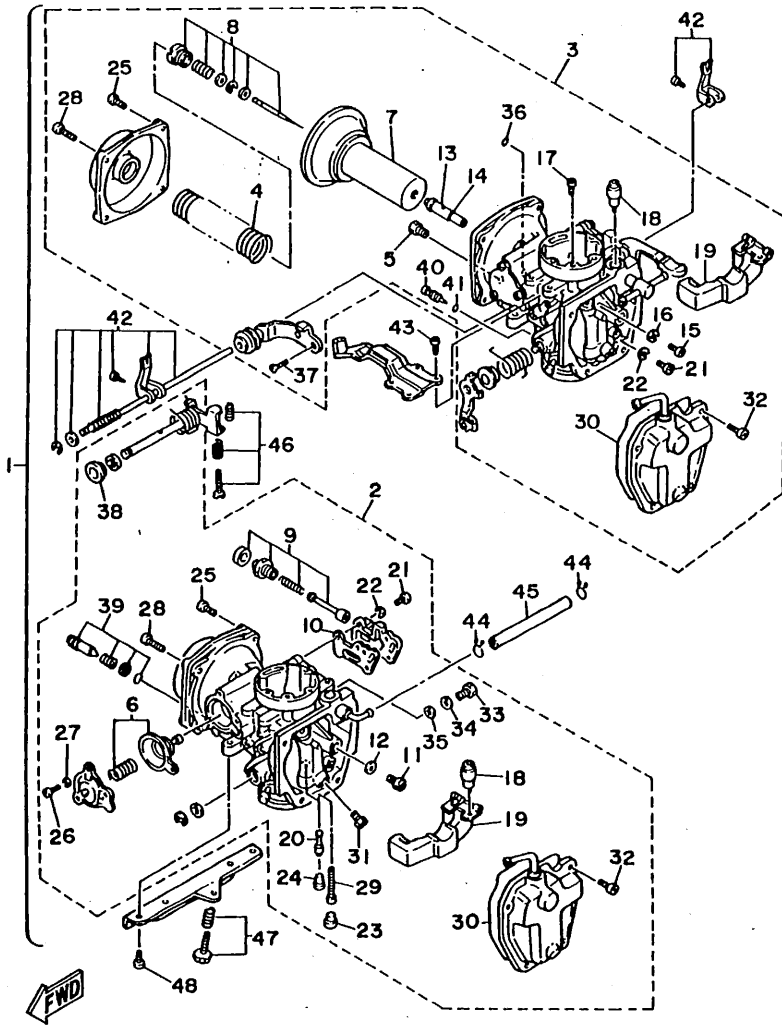

REF. NO.	PART NO.	DESCRIPTION	Q'TY	REMARKS
28	90157-05050	..SCREW, pan head	1	
29	2JU-1414G-00	..PIPE, main breed	1	
30	22V-14147-00	..O-RING	1	
31	3G2-14231-27	..JET, main (#135)	1	
32	98501-05012	..SCREW, pan head	4	
33	341-14991-00	..SCREW	1	
34	26H-14952-00	..WASHER	1	
35	22U-14952-00	..WASHER	1	
36	93210-03119	..O-RING	1	
37	98701-06010	..SCREW, flat head	2	
38	341-14954-00	..WASHER	1	
39	12R-14105-00	..PILOT SCREW SET	1	
40	2L1-14191-00	..PLUG, drain	1	
41	214-14147-00	..O-RING	1	
42	26V-1490L-00	..STARTER LEVER SET, 1	1	
43	98501-05010	..SCREW, pan head	4	
44	90467-10008	..CLIP	2	
45	31H-14987-00	..HOSE	1	
46	22U-1490K-00	..STOP SCREW SET	1	
47	22U-14103-00	..THROTTLE SCREW SET	1	
48	98580-06012	..SCREW, pan head	4	

3BT8332-0090

B12

FIG. 10 EXHAUST

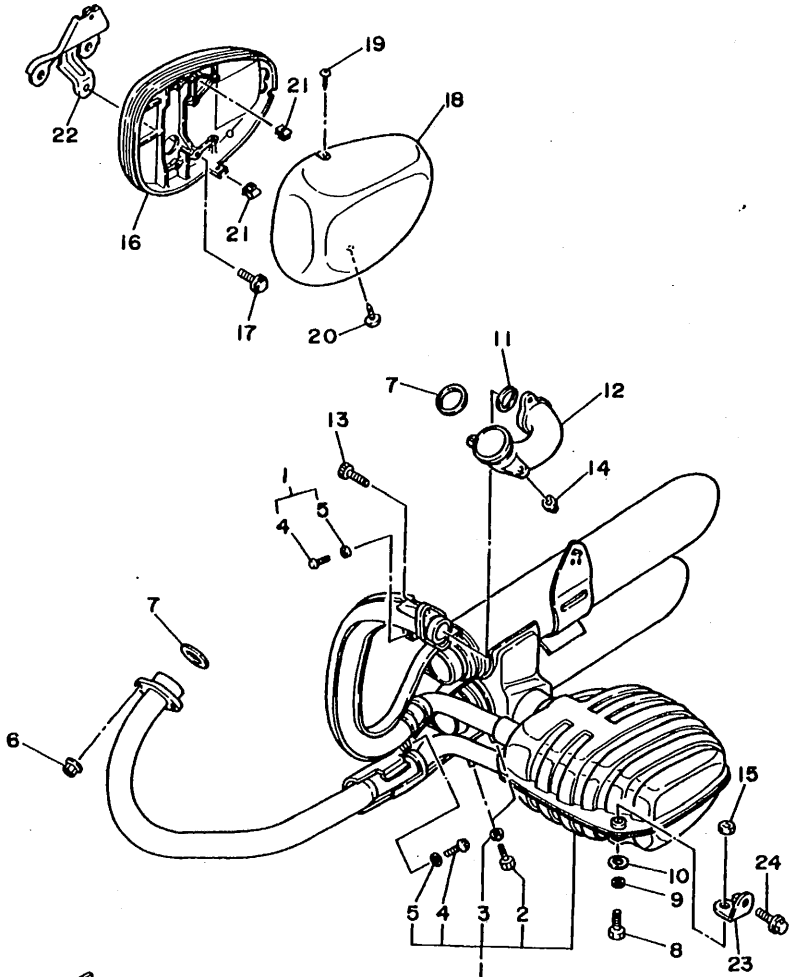

REF. NO.	PART NO.	DESCRIPTION	Q'TY	REMARKS
1	2YL-14703-10	MUFFLER COMP 1	1	
2	90101-06576	.BOLT	2	
3	92906-06600	.WASHER, plate	2	
4	98580-06020	.SCREW, pan head	2	
5	92901-06600	.WASHER, plate	2	
6	90179-08410	NUT	2	
7	4BE-14613-00	GASKET, exhaust pipe	2	
8	97026-08030	BOLT	1	
9	92906-08700	WASHER	1	
10	92906-08600	WASHER, plate	1	
11	4BR-14613-00	GASKET, exhaust pipe	1	
12	2GV-14625-00	JOINT, exhaust 2	1	
13	91311-06025	BOLT	2	
14	90185-08097	NUT, self-locking	2	
15	95316-08700	NUT	1	
16	2GV-14663-00	PLATE, air cleaner	1	
17	95801-06016	BOLT, flange	2	
18	2GV-14603-00	COVER 1	1	
19	97701-40012	SCREW, tapping	1	
20	90163-04003	SCREW, tapping	1	
21	90183-04027	NUT, spring	2	
22	2GV-14484-00	PLATE, cleaner case fitting	1	
23	2GV-2138L-00	BRACKET 2	1	
24	95816-08016	BOLT, flange	1	



38T3351-9100

B13

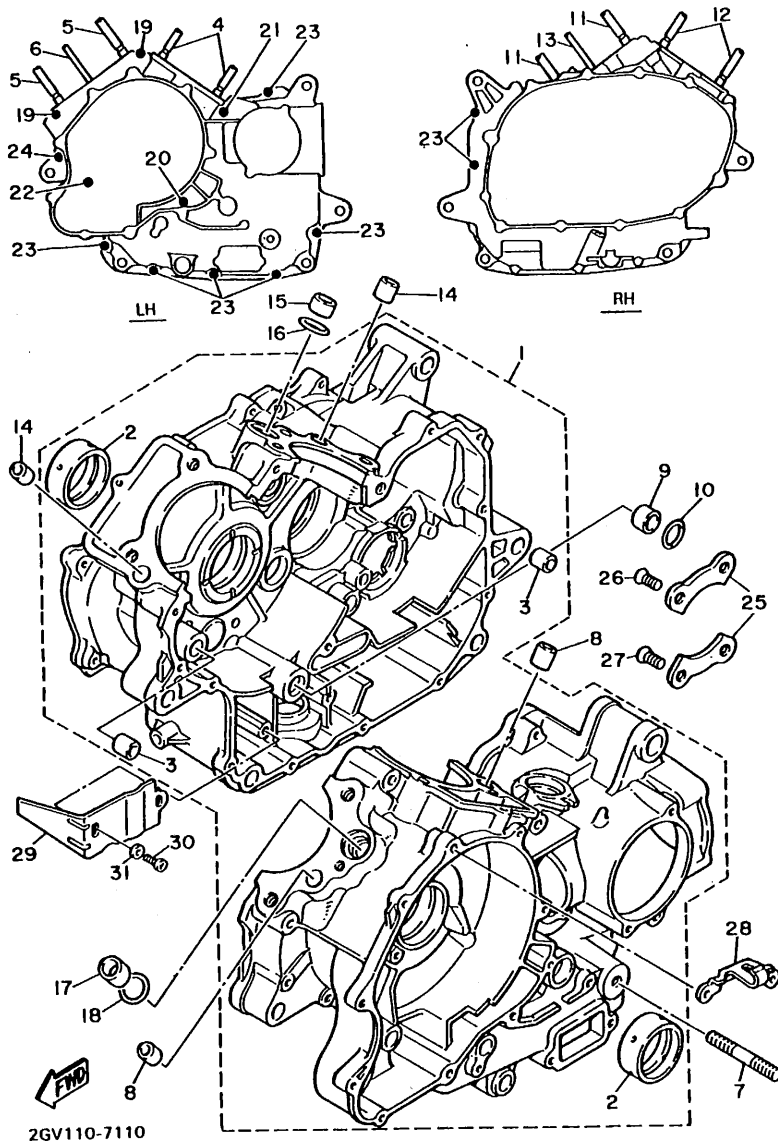

FIG. 11 CRANKCASE

REF. NO.	PART NO.	DESCRIPTION	Q'TY	REMARKS
1	2GV-15100-00	CRANKCASE ASSY	1	
2	22U-11416-80	.PLANE BEARING, crankshaft 1	2	UR BLUE
	22U-11416-90	.PLANE BEARING, crankshaft 1	2	UR GREEN
3	91810-17016	.PIN, dowel	2	
4	90116-10406	BOLT; stud	2	
5	90116-10405	BOLT, stud	2	
6	90116-08404	BOLT, stud	1	
7	95611-10680	BOLT, stud	1	
8	99530-14016	PIN, dowel	2	
9	90387-16547	COLLAR	1	
10	93210-18322	O-RING	1	
11	90116-10406	BOLT, stud	2	
12	90116-10405	BOLT, stud	2	
13	90116-08404	BOLT, stud	1	
14	99530-14016	PIN, dowel	2	
15	90387-16547	COLLAR	1	
16	93210-18322	O-RING	1	
17	90387-16547	COLLAR	1	
18	93210-18322	O-RING	1	
19	91311-08060	BOLT	2	
20	91311-08080	BOLT	1	
21	91311-08100	BOLT	1	
22	91311-06095	BOLT	1	
23	91311-06045	BOLT	8	
24	91311-06055	BOLT	1	
25	11H-15383-01	PLATE, bearing cover	2	
26	90151-08022	SCREW, countersunk	1	
27	90149-08152	SCREW	3	

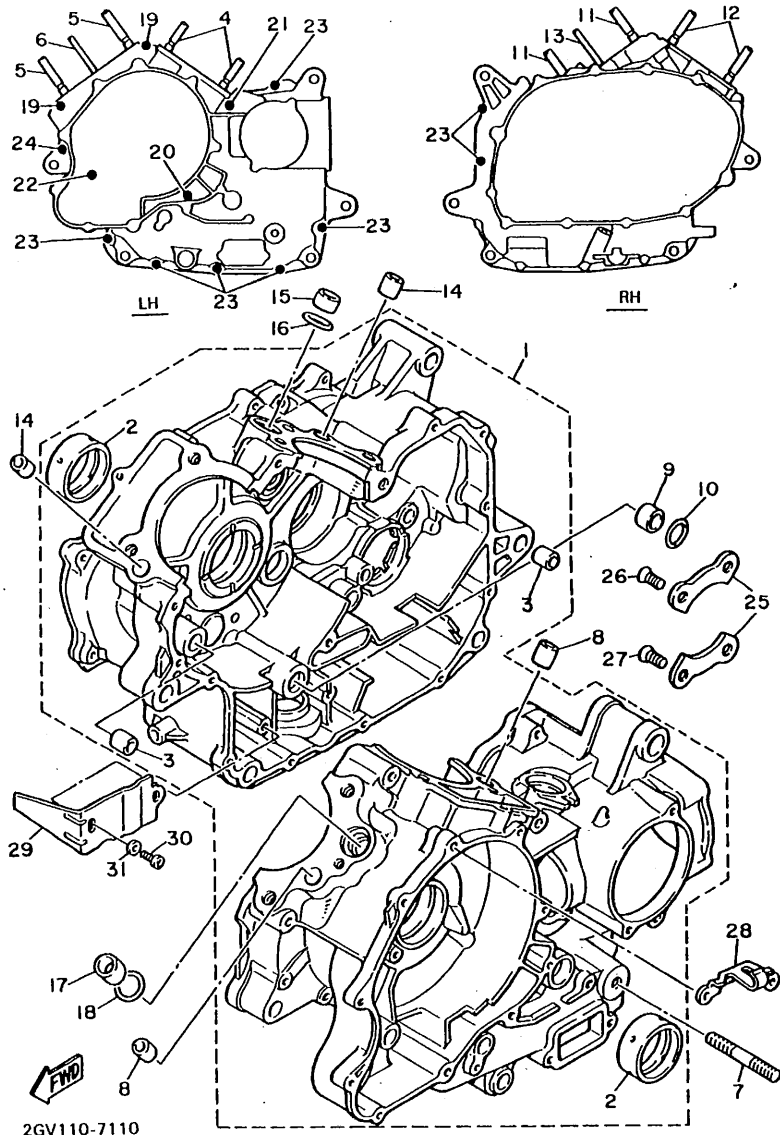
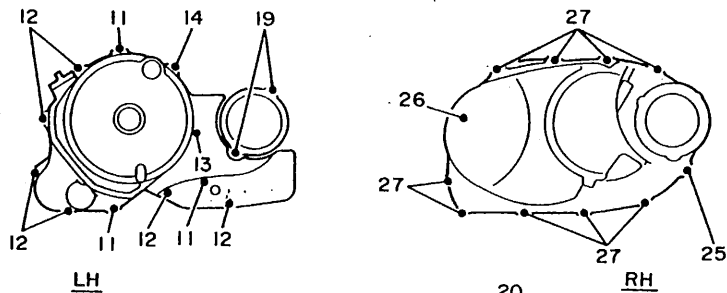

FIG. 11 CRANKCASE

REF. NO.	PART NO.	DESCRIPTION	Q'TY	REMARKS
28	22U-15441-01	HOLDER, clutch cable	1	
29	22U-15123-00	PLATE, baffle 1	1	
30	98501-06012	SCREW, pan head	2	
31	92901-06600	WASHER, plate	2	

26V110-7110

B15



LH

RH

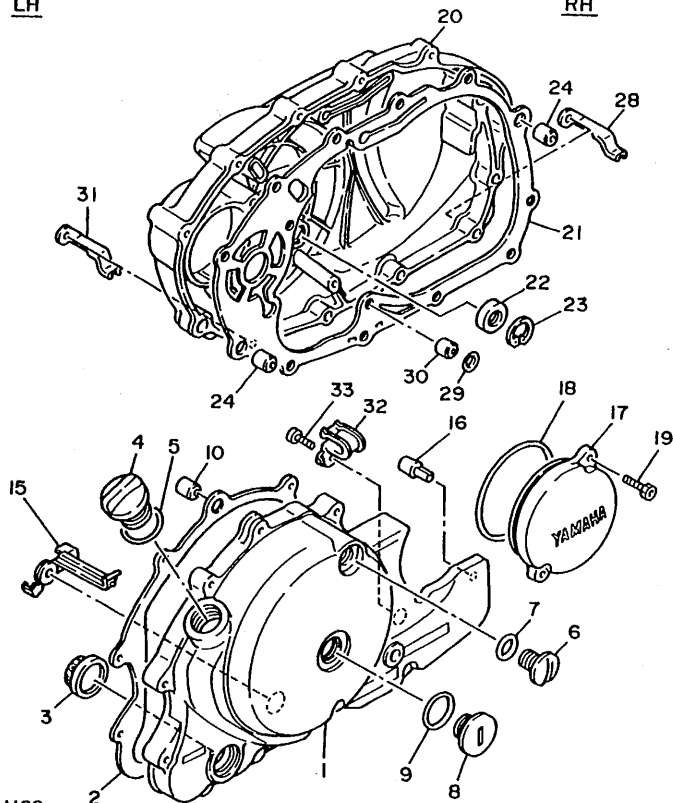

3BM5361-1120

FIG. 12 CRANKCASE COVER 1

REF. NO.	PART NO.	DESCRIPTION	Q'TY	REMARKS
1	2NT-15411-01	COVER, crankcase 1	1	
2	3BT-15451-00	GASKET, crankcase cover 1	1	
3	2H7-15361-00	GAUGE, level	1	
4	3F9-15362-00	PLUG, oil level	1	
5	93210-27778	O-RING	1	
6	90340-14068	PLUG, straight screw	1	
7	93210-14369	O-RING	1	
8	90340-32088	PLUG, straight screw	1	
9	93210-32172	O-RING	1	
10	99530-10014	PIN, dowel	2	
11	91311-06040	BOLT	3	
12	91311-06025	BOLT	6	
13	91311-06055	BOLT	1	
14	91311-06030	BOLT	1	
15	3BT-15484-00	CLAMP 2	1	
16	2GV-15316-00	DAMPER, engine mount 1	1	
17	2NT-15415-00	COVER, generator	1	
18	93210-74316	O-RING	1	
19	91311-06018	BOLT	2	
20	2NT-15421-00	COVER, crankcase 2	1	
21	3BT-15461-00	GASKET, crankcase cover 2	1	
22	93101-14089	OIL SEAL	1	
23	99009-25500	CIRCLIP	1	
24	99530-10020	PIN, dowel	2	
25	91311-06040	BOLT	1	
26	91311-06055	BOLT	1	
27	91311-06025	BOLT	9	
28	90462-10115	CLAMP	2	

C2

FIG. 12 CRANKCASE COVER 1

REF. NO.	PART NO.	DESCRIPTION	Q'TY	REMARKS
29	93210-15566	O-RING	1	
30	91810-17016	PIN, dowel	1	
31	90462-10118	CLAMP	2	
32	90462-06119	CLAMP	1	
33	98501-06010	SCREW, pan head	1	

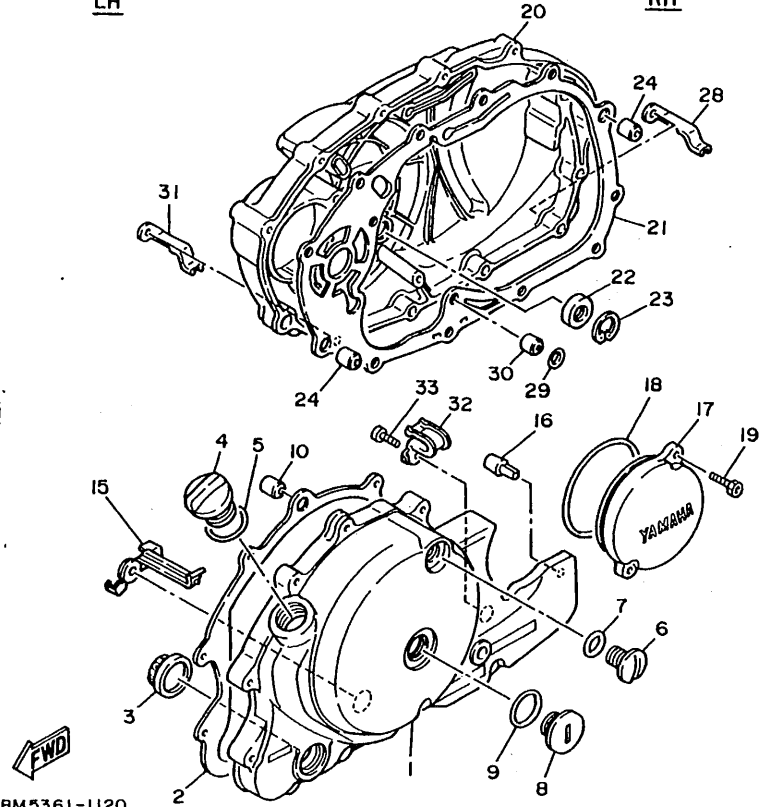
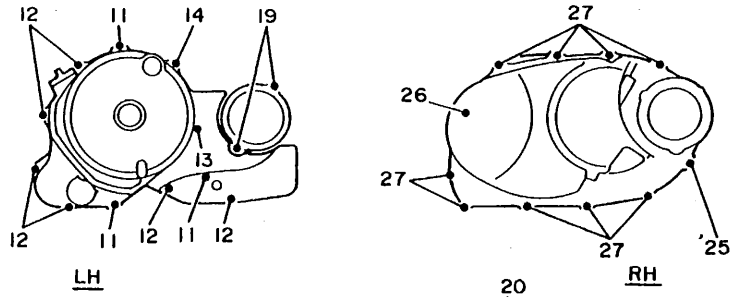

38M5361-1120

C3

FIG. 13 STARTER CLUTCH

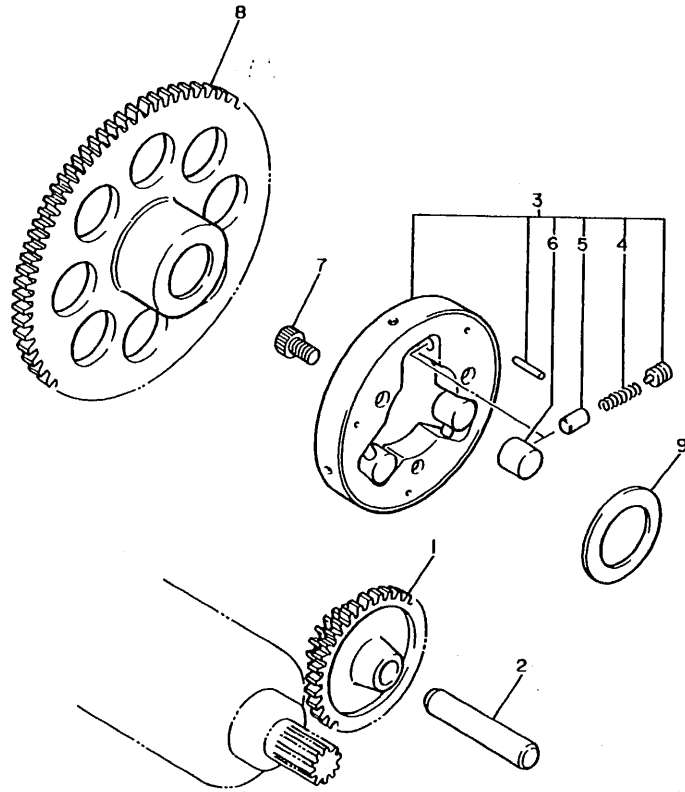

REF. NO.	PART NO.	DESCRIPTION	Q'TY	REMARKS
1	22U-15512-00	GEAR, idler 1 (12T-50T)	1	
2	5H0-15521-00	SHAFT 1	1	
3	22U-15580-00	STARTER CLUTCH OUTER ASSY	1	
4	90501-04623	.SPRING, compression	3	
5	341-15583-05	.CAP, starter clutch spring	3	
6	93615-12088	.PIN, dowel	3	
7	91316-08012	BOLT	3	
8	22U-15517-00	GEAR, idler 2 (66T)	1	
9	4A0-17216-00-10	SHIM (1.0T)	1	



22U110-3150

C4

FIG. 14 CLUTCH

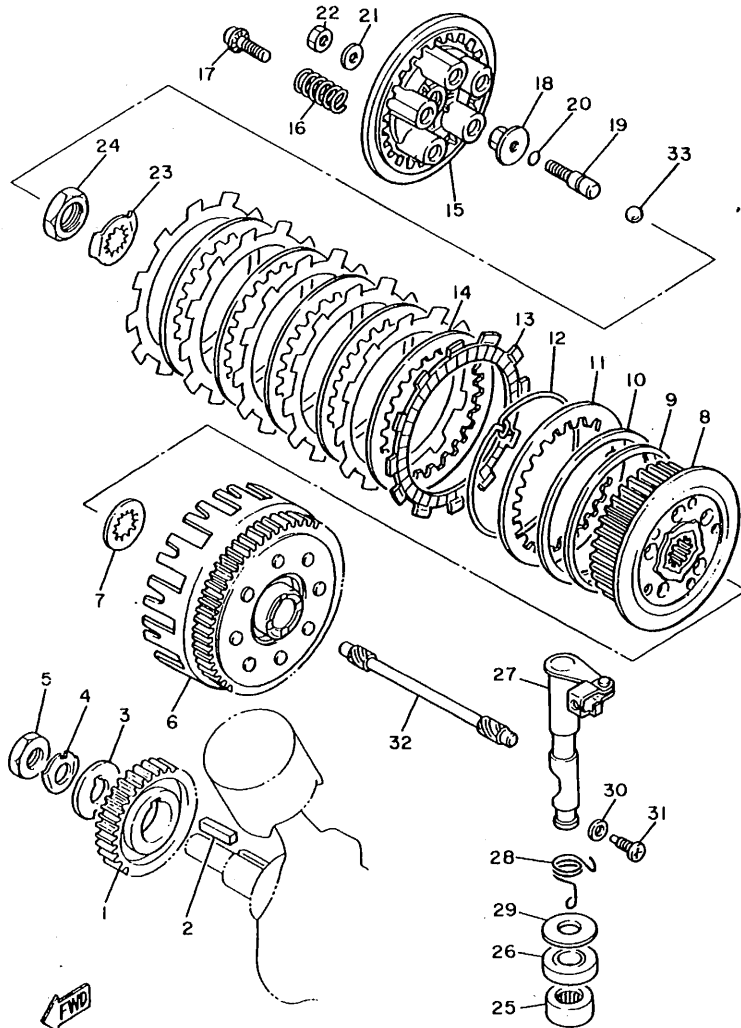

REF. NO.	PART NO.	DESCRIPTION	Q'TY	REMARKS
1	22U-16111-01	GEAR, primary drive	1	
2	90280-07036	KEY, woodruff	1	
3	90214-16026	WASHER, claw	1	
4	90215-16222	WASHER, lock	1	
5	90170-16311	NUT	1	
6	22U-16150-01	PRIMARY DRIVEN GEAR COMP.	1	
7	22U-16154-00	PLATE, thrust 1	1	
8	22U-16371-00	BOSS, clutch	1	
9	4X7-16384-00	PLATE, seat	1	
10	4X7-16383-01	SPRING, clutch boss	1	
11	4X7-16324-00	PLATE, clutch 1	1	
12	4X7-16385-00	RING, clutch boss	1	
13	22U-16321-00	PLATE, friction	6	
14	4X7-16325-00	PLATE, clutch 2	5	
15	22U-16351-00	PLATE, pressure 1	1	
16	90501-23738	SPRING, compression	5	
17	90159-06016	SCREW, with washer	5	
18	30X-16358-00	PLATE, push	1	
19	5Y1-16356-00	ROD, push 1	1	
20	93210-09525	O-RING	1	
21	92901-06200	WASHER, plain	1	
22	95303-06600	NUT	1	
23	90215-22244	WASHER, lock	1	
24	90170-20310	NUT	1	
25	93315-21813	BEARING, cylindrical	1	
26	93102-18278	OIL SEAL	1	
27	22U-16380-00	PUSH LEVER ASSY	1	
28	90508-16577	SPRING, torsion	1	

C5

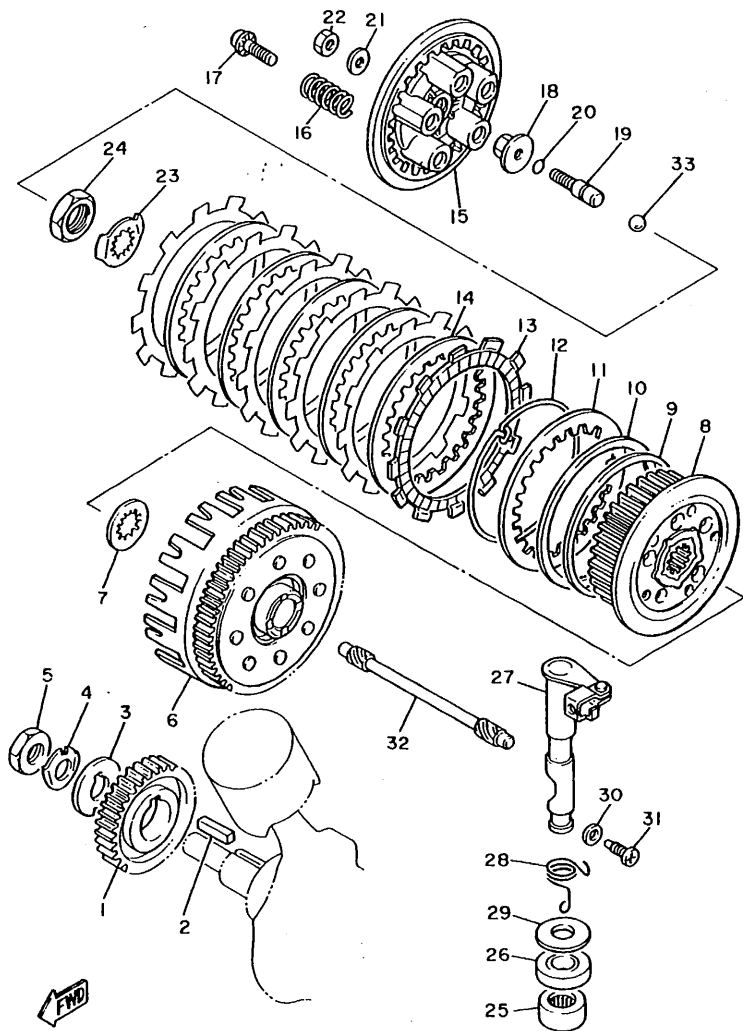

22U110-3160

FIG. 14 CLUTCH

REF. NO.	PART NO.	DESCRIPTION	Q'TY	REMARKS
29	90201-18262	WASHER, plate	1	
30	90201-08087	WASHER, plate	1	
31	90149-08067	SCREW	1	
32	22U-16357-00	ROD, push 2	1	
33	93515-32029	BALL	1	

FIG. 15 TRANSMISSION

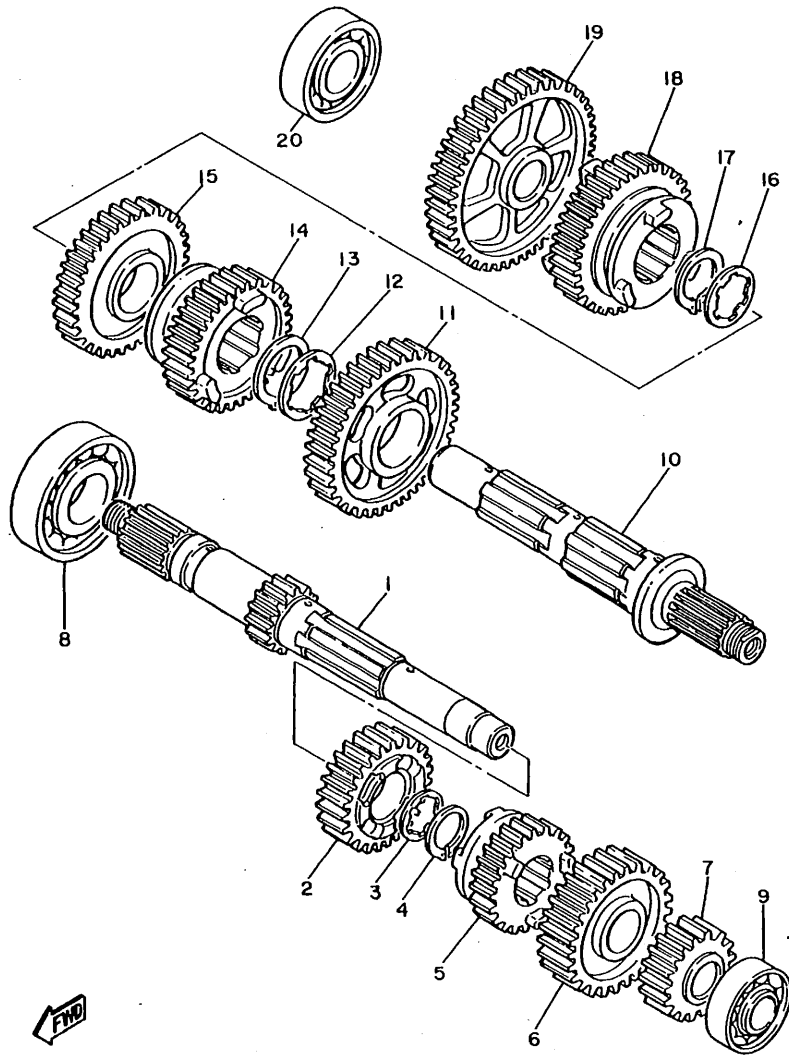

REF. NO.	PART NO.	DESCRIPTION	Q'TY	REMARKS
1	22U-17411-00	AXLE, main (14T)	1	
2	22U-17141-00	GEAR, 4th pinion (24T)	1	
3	90209-22191	WASHER	1	
4	93440-25084	CIRCLIP	1	
5	22U-17131-00	GEAR, 3rd pinion (24T)	1	
6	11H-17151-01	GEAR, 5th pinion (30T)	1	
7	11H-17121-00	GEAR, 2nd pinion (20T)	1	
8	93306-30525	BEARING (B6305)	1	
9	93306-00401	BEARING (B6004)	1	
10	22U-17402-00	DRIVE AXLE ASSY	1	
11	22U-17221-00	GEAR, 2nd wheel (38T)	1	
12	90209-27192	WASHER	1	
13	93440-30077	CIRCLIP	1	
14	11H-17251-00	GEAR, 5th wheel (29T)	1	
15	22U-17231-00	GEAR, 3rd wheel (35T)	1	
16	90209-22191	WASHER	1	
17	93440-25084	CIRCLIP	1	
18	22U-17241-00	GEAR, 4th wheel (28T)	1	
19	22U-17211-00	GEAR, 1st wheel (38T)	1	
20	93306-00428	BEARING	1	



2GV110-7150

C7

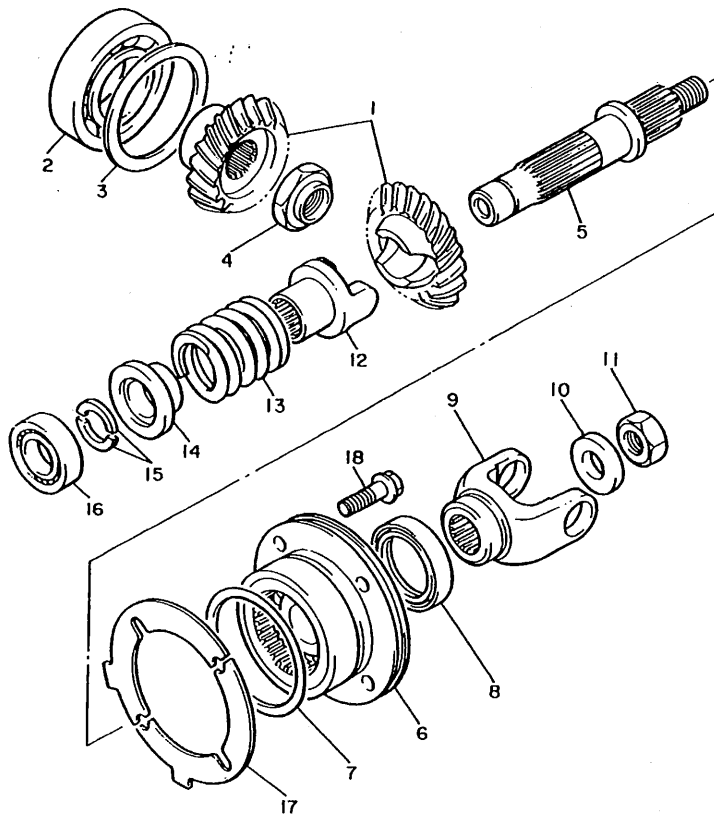

22U110-3180

FIG. 16 MIDDLE DRIVE GEAR

REF. NO.	PART NO.	DESCRIPTION	Q'TY	REMARKS
1	22U-Y1754-00	MIDDLE GEAR COMP.	1	
2	93306-20711	BEARING	1	
3	4H7-17537-00-20	SHIM, thrust (0.20T)	1	UR
	4H7-17537-00-30	SHIM, thrust (0.30T)	1	UR
	4H7-17537-00-40	SHIM, thrust (0.40T)	1	UR
4	90179-18396	NUT	1	
5	22U-17553-00	SHAFT, middle driven	1	
6	4H7-W1752-10	HOUSHING COMP	1	
7	93210-71360	O-RING	1	
8	93101-35097	OIL SEAL	1	
9	22U-17556-00	YOKE, joint	1	
10	90201-14633	WASHER, plate	1	
11	90185-14070	NUT, self-locking	1	
12	22U-17527-00	CAM, driven	1	
13	90501-60716	SPRING, compression	1	
14	22U-17524-00	HOLDER	1	
15	3H5-17529-00	WASHER, thrust	2	
16	93306-00435	BEARING	1	
17	3JB-17531-00	SHIM, pinion (0.10T)	2	UR
	3JB-17531-10	SHIM, pinion (0.15T)	2	UR
	3JB-17531-20	SHIM, pinion (0.20T)	2	UR
	3JB-17531-30	SHIM, pinion (0.30T)	2	UR
	3JB-17531-40	SHIM, pinion (0.40T)	2	UR
	3JB-17531-50	SHIM, pinion (0.50T)	2	UR
18	95811-08030	BOLT, flange	4	

FIG. 17 SHIFT CAM. FORK

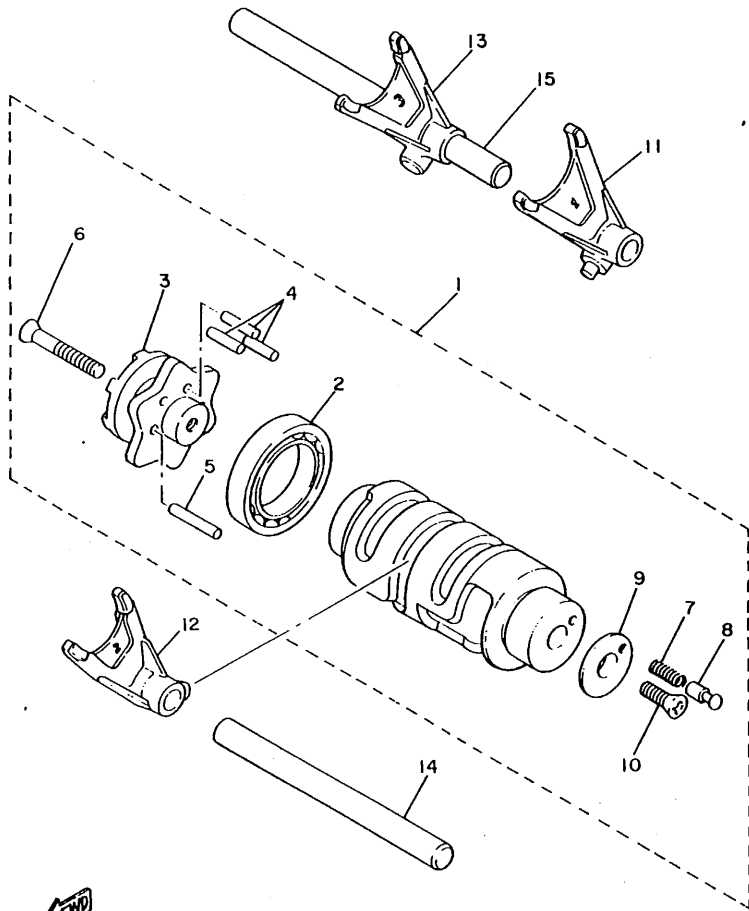

REF. NO.	PART NO.	DESCRIPTION	Q'TY	REMARKS
1	22U-18540-00	SHIFT CAM ASSY	1	
2	93306-90602	.BEARING	1	
3	16G-18185-00	.SEGMENT	1	
4	93604-16092	.PIN, dowel	3	
5	93604-20156	.PIN, dowel	1	
6	98701-05035	.SCREW, flat head	1	
7	90501-06022	.SPRING, compression	1	
8	278-18542-00	.POINT, neutral	1	
9	278-18566-00	.PLATE, side 2	1	
10	98701-05016	.SCREW, flat head	1	
11	11H-18511-00	FORK, shift 1	1	
12	11H-18512-00	FORK, shift 2	1	
13	11H-18513-00	FORK, shift 3	1	
14	11H-18531-00	BAR, shift fork guide 1	1	
15	22U-18535-00	BAR, shift fork guide 2	1	



22U110:3190

C9

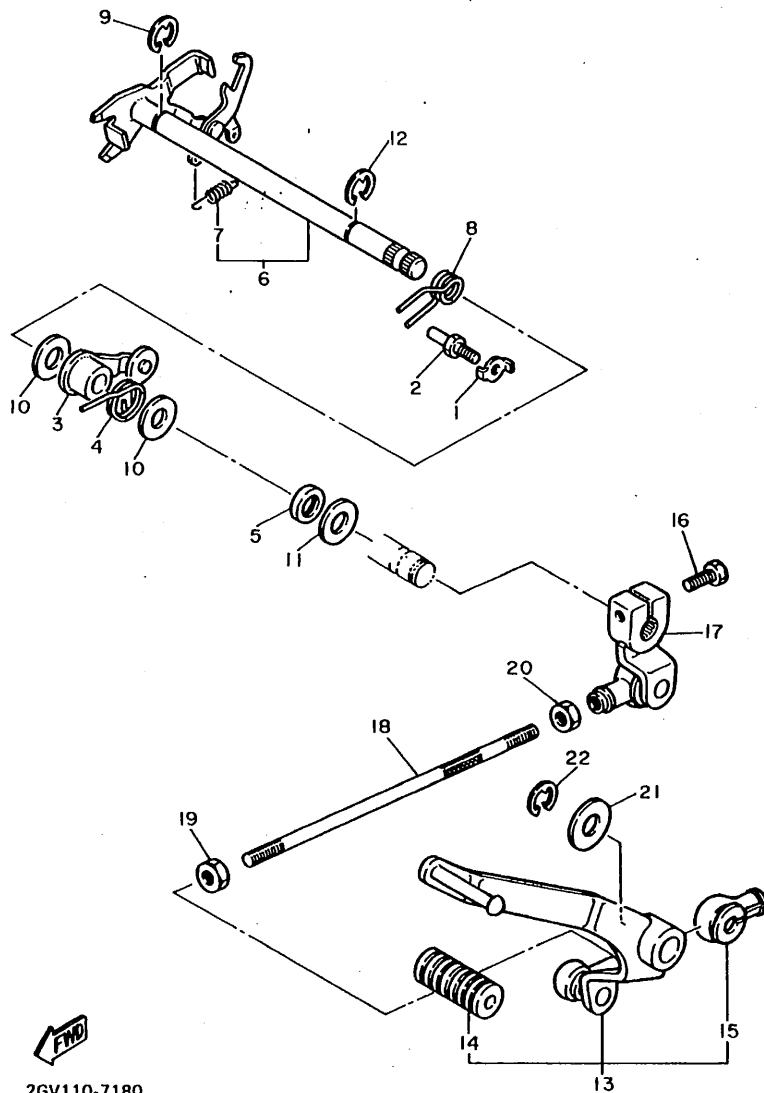

2GV110-7180

FIG. 18 SHIFT SHAFT

REF. NO.	PART NO.	DESCRIPTION	Q'TY	REMARKS
1	90215-18178	WASHER, lock	1	
2	460-18127-00	STOPPER, screw	1	
3	11H-18140-00	STOPPER LEVER ASSY	1	
4	90508-29519	SPRING, torsion	1	
5	93102-12106	OIL SEAL (SD 12-22-5 HS)	1	
6	22U-18120-00	SHIFT LEVER ASSY	1	
7	90506-08227	.SPRING, tension	1	
8	90508-32536	SPRING, torsion	1	
9	99006-10600	CIRCLIP	1	
10	90201-12588	WASHER, plate	2	
11	90201-12575	WASHER, plate	1	
12	99006-10600	CIRCLIP	1	
13	2GV-18110-00	SHIFT PEDAL ASSY	1	
14	132-18113-01	.COVER, shift pedal	1	
15	2H9-18154-00	.COVER, dust	1	
16	97011-06020	BOLT	1	
17	2GV-18112-00	ARM, shift	1	
18	2GV-18115-00	ROD, shift	1	
19	90170-06228	NUT	1	
20	95303-06700	NUT	1	
21	90201-124E4	WASHER, plate	1	
22	99009-12400	CIRCLIP	1	

C10

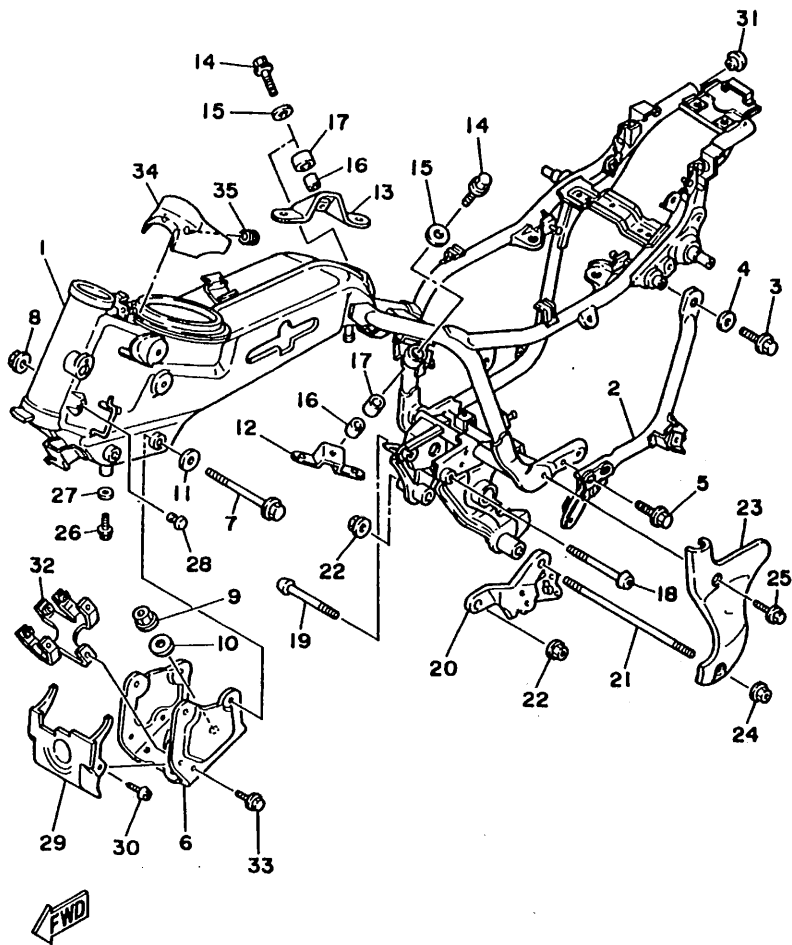

3JC4171-0190

FIG. 19 FRAME

REF. NO.	PART NO.	DESCRIPTION	Q'TY	REMARKS
1	3BT-21110-10-33	FRAME COMP.	1	YAMAHA BLACK
2	3JB-21105-00-33	BACK STAY SUB COMP. 1	1	YAMAHA BLACK
3	90105-08177	BOLT, washer based	1	
4	90201-081H4	WASHER, plate	1	
5	90109-08718	BOLT	2	
6	2GV-21317-00	STAY, engine 4	1	
7	90105-10183	BOLT, washer based	2	
8	90179-10321	NUT	2	
9	90179-10279	NUT	4	
10	90201-10131	WASHER, plate	4	
11	90201-10437	WASHER, plate	2	
12	22U-21315-00	STAY, engine 2	1	
13	22U-21316-00	STAY, engine 3	1	
14	90105-10186	BOLT, washer based	2	
15	90201-105H3	WASHER, plate	2	
16	90387-100E2	COLLAR	2	
17	4X7-21485-00	DAMPER, rubber 1	2	
18	90149-10238	SCREW	1	
19	90149-10239	SCREW	1	
20	2GV-21458-00	BRACKET, side stand	1	
21	90116-12495	BOLT, stud	1	
22	90179-12421	NUT	2	
23	2GV-2171E-00	COVER, side 5	1	
24	95306-12800	NUT	1	
25	95026-06016	BOLT, flange	1	
26	90105-06069	BOLT, washer based	1	
27	90202-06010	WASHER, plate	1	
28	90338-07043	PLUG	5	

C11

FIG. 19 FRAME

REF. NO.	PART NO.	DESCRIPTION	Q'TY	REMARKS
29	2GV-2139R-00	COVER 2	1	
30	97706-60514	SCREW, tapping	2	
31	1AA-2143A-00	CAP	2	
32	2GV-21359-00	BRACKET, coil	1	
33	95816-06012	BOLT, flange	2	
34	3JB-2139R-00	COVER 2	1	
35	90480-10334	GROMMET	2	

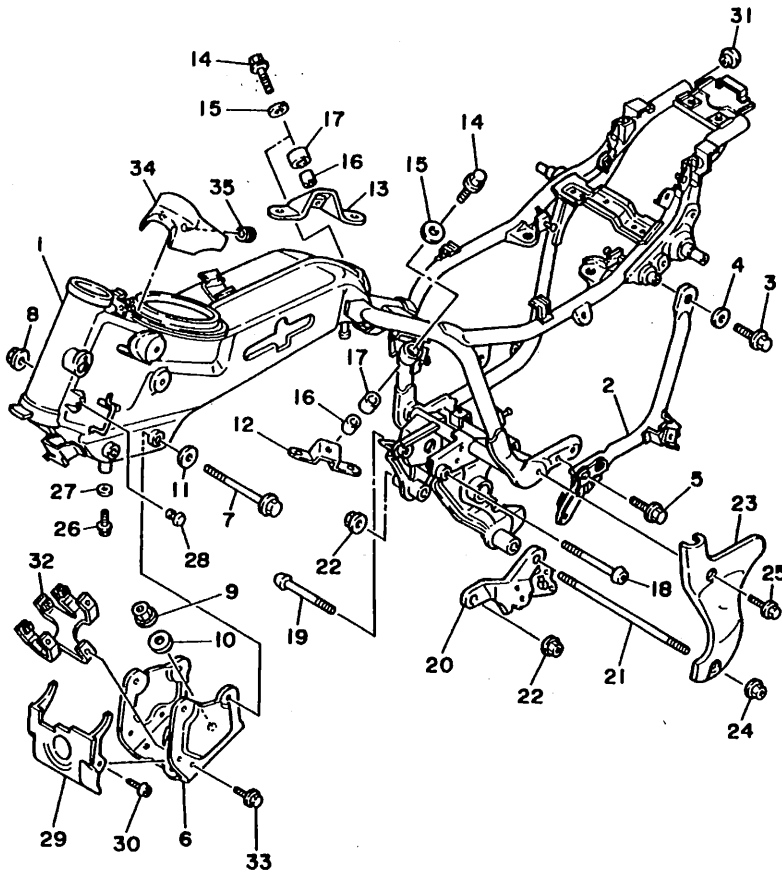

FWD

3JC4171-0190

FIG. 20 FENDER

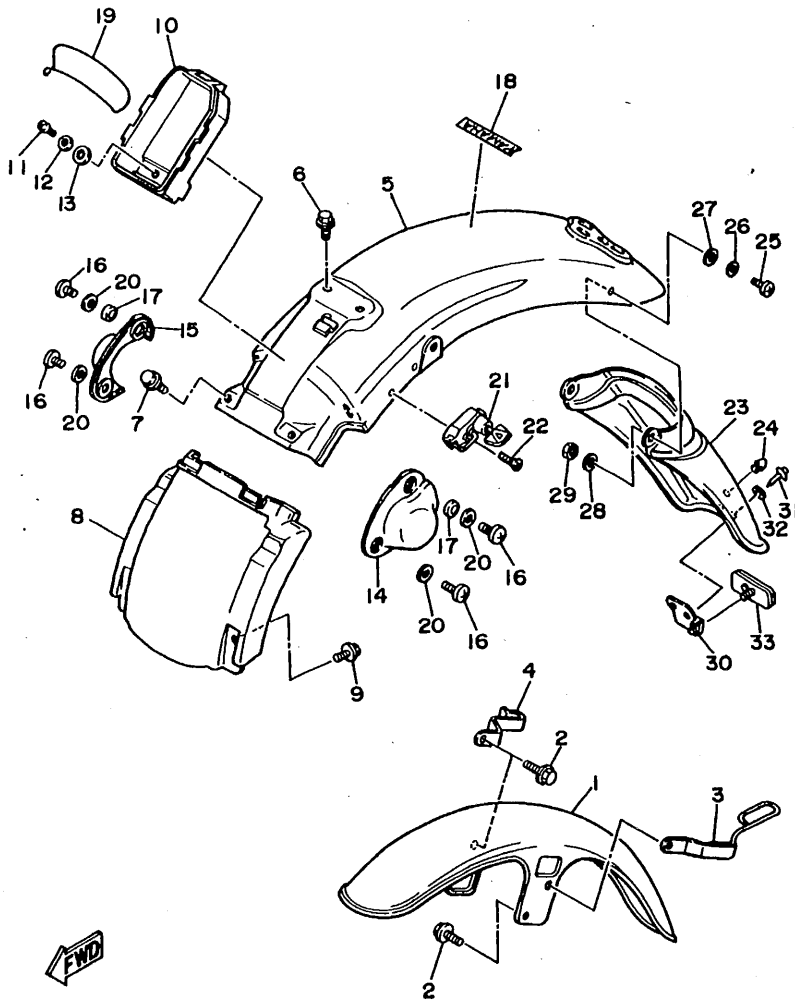

3BT8332-0200

REF. NO.	PART NO.	DESCRIPTION	Q'TY	REMARKS
1	2GV-21510-00-P0	FRONT FENDER COMP.	1	UR LIGHT GRAYISH BLUE METALLIC 1
	2GV-21510-00-R0	FRONT FENDER COMP.	1	UR GRACEFUL MAROON
	2GV-21510-00-4B	FRONT FENDER COMP.	1	UR BLACK 2
2	95023-08012	BOLT	4	
3	2NT-21597-01	HOLDER, wire 1	1	
4	2NT-21598-00	HOLDER, wire 2	1	
5	3BR-21610-00-P0	REAR FENDER COMP.	1	UR LIGHT GRAYISH BLUE METALLIC 1
	3BR-21610-00-R0	REAR FENDER COMP.	1	UR GRACEFUL MAROON
	3BR-21610-00-4B	REAR FENDER COMP.	1	UR BLACK 2
6	95816-08012	BOLT, flange	2	
7	95826-06010	BOLT, flange	2	
8	2GV-21629-00-P0	GUARD, mud	1	UR LIGHT GRAYISH BLUE METALLIC 1
	2GV-21629-00-R0	GUARD, mud	1	UR GRACEFUL MAROON
	2GV-21629-00-4B	GUARD, mud	1	UR BLACK 2
9	90119-06123	BOLT, with washer	2	
10	2GV-2160E-00	BOX	1	
11	98506-06014	SCREW, pan head	1	
12	92906-06600	WASHER, plate	1	
13	90201-06059	WASHER, plate	1	
14	2GV-2163A-00	COVER, rear fender 1	1	
15	2GV-2163E-00	COVER, rear fender 2	1	
16	98903-08014	SCREW, bind	4	
17	90560-08326	SPACER	2	
18	99235-00080	EMBLEM, yamaha	1	UR FOR GRM, BL2
	99234-00080	EMBLEM, yamaha	1	UR FOR LGBM1
19	93210-71360	O-RING	1	
20	92901-08200	WASHER, plain	4	
21	26H-21308-00	HELMET HANGER ASSY	1	

C13

FIG. 20 FENDER

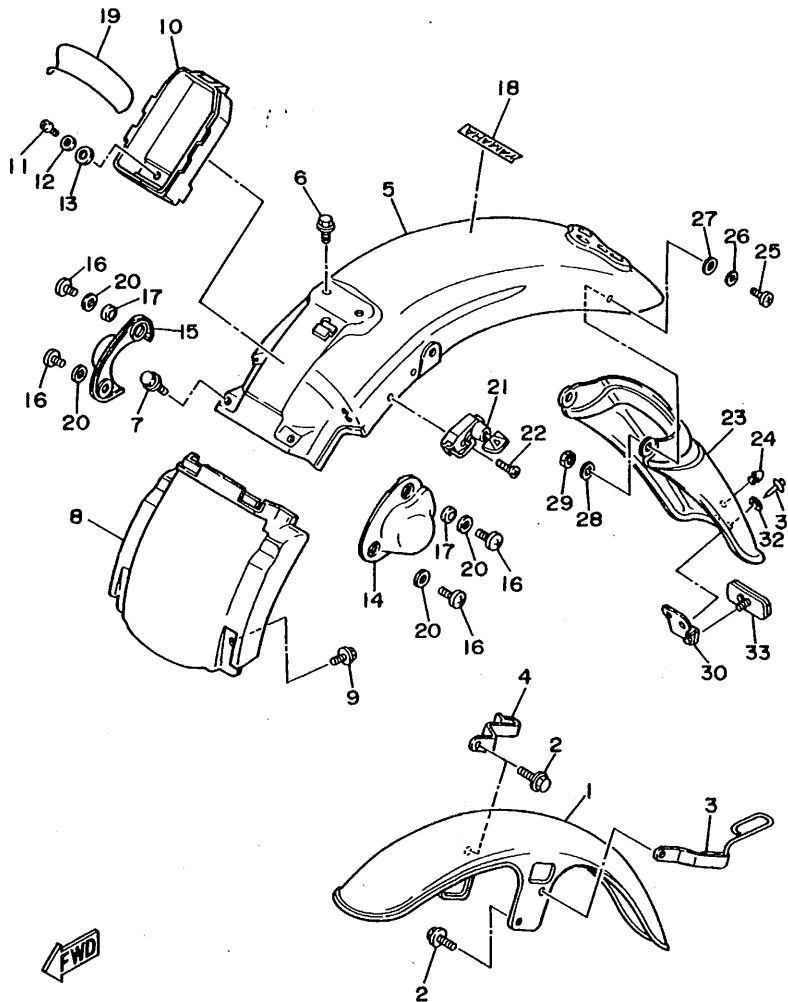

REF. NO.	PART NO.	DESCRIPTION	Q'TY	REMARKS
22	90149-06154	SCREW	1	
23	3BR-21621-00	FLAP	1	
24	4G0-21639-00	DAMPER 2	1	
25	92506-06012	SCREW, pan head	2	
26	92906-06600	WASHER, plate	2	
27	90430-06139	GASKET	2	
28	92990-06200	WASHER, plain	2	
29	95303-06600	NUT	2	
30	2AE-21641-00	BRACKET, reflector	1	
31	90267-40076	RIVET, blind	2	
32	90201-044A2	WASHER, plate	2	
33	449-85131-02	REFLECTOR, rear 1	1	

3BT8332-0200

C14

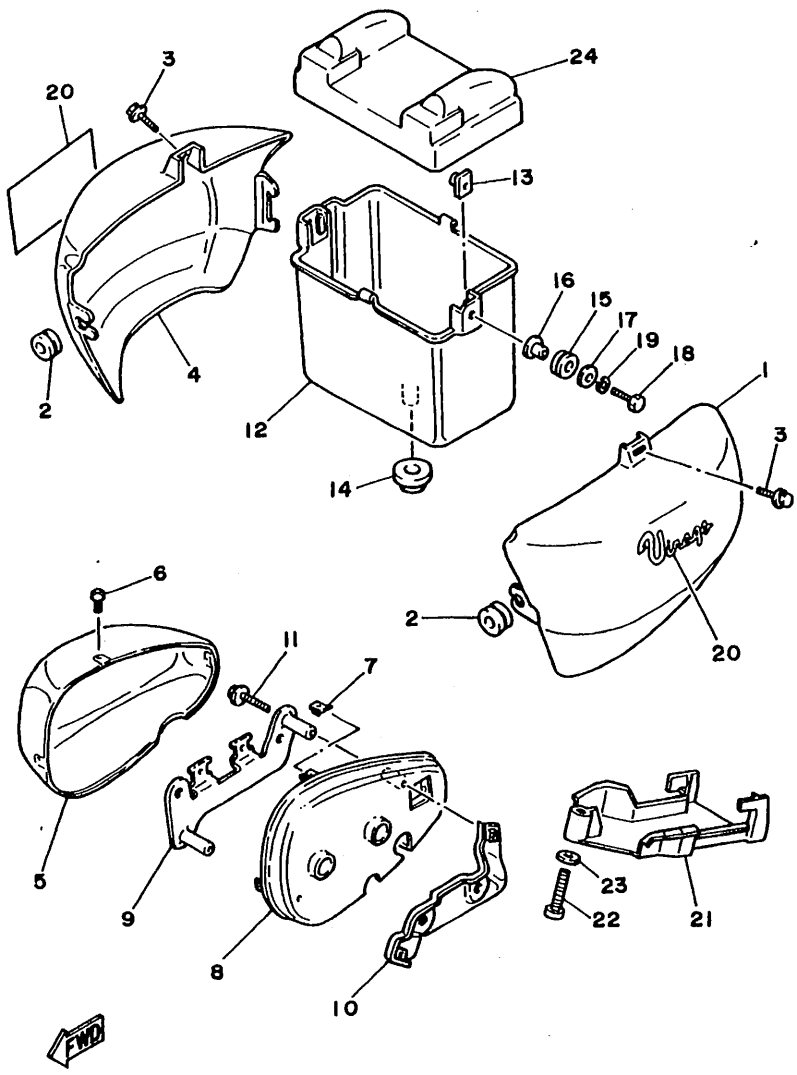

3BT3351-9210

FIG. 21 SIDE COVER

REF. NO.	PART NO.	DESCRIPTION	Q'TY	REMARKS
1	2GV-21711-00-P0	COVER, side 1	1	UR LIGHT GRAYISH BLUE METALLIC 1
	2GV-21711-00-R0	COVER, side 1	1	UR GRACEFUL MAROON
	2GV-21711-00-4B	COVER, side 1	1	UR BLACK 2
2	90480-12320	GROMMET	2	
3	90119-06123	BOLT, with washer	2	
4	2GV-21721-00-P0	COVER, side 2	1	UR LIGHT GRAYISH BLUE METALLIC 1
	2GV-21721-00-R0	COVER, side 2	1	UR GRACEFUL MAROON
	2GV-21721-00-4B	COVER, side 2	1	UR BLACK 2
5	2GV-21731-00-93	COVER, side 3	1	CHROME PLATED
6	97701-40012	SCREW, tapping	3	
7	90183-04027	NUT, spring	3	
8	2GV-2172A-00	PANEL 1	1	
9	2GV-2172F-00	PANEL 2	1	
10	2GV-2174E-00	STAY, side cover 2	1	
11	95806-06040	BOLT, flange	2	
12	2GV-21171-00	BOX, tool	1	
13	31A-14477-00	PLATE	2	
14	90480-22362	GROMMET	1	
15	90480-14229	GROMMET	2	
16	90387-07391	COLLAR	2	
17	90201-06059	WASHER, plate	2	
18	97001-06025	BOLT	2	
19	92906-06100	WASHER, spring	2	
20	3BT-21781-30	EMBLEM 1	2	UR FOR LGBM1
	3BT-21781-40	EMBLEM 1	2	UR FOR BL2
	3BT-21781-50	EMBLEM 1	2	UR FOR GRM
21	3JB-2176E-00	PLATE	1	
22	92506-06035	SCREW, pan head	1	

C15

FIG. 21 SIDE COVER

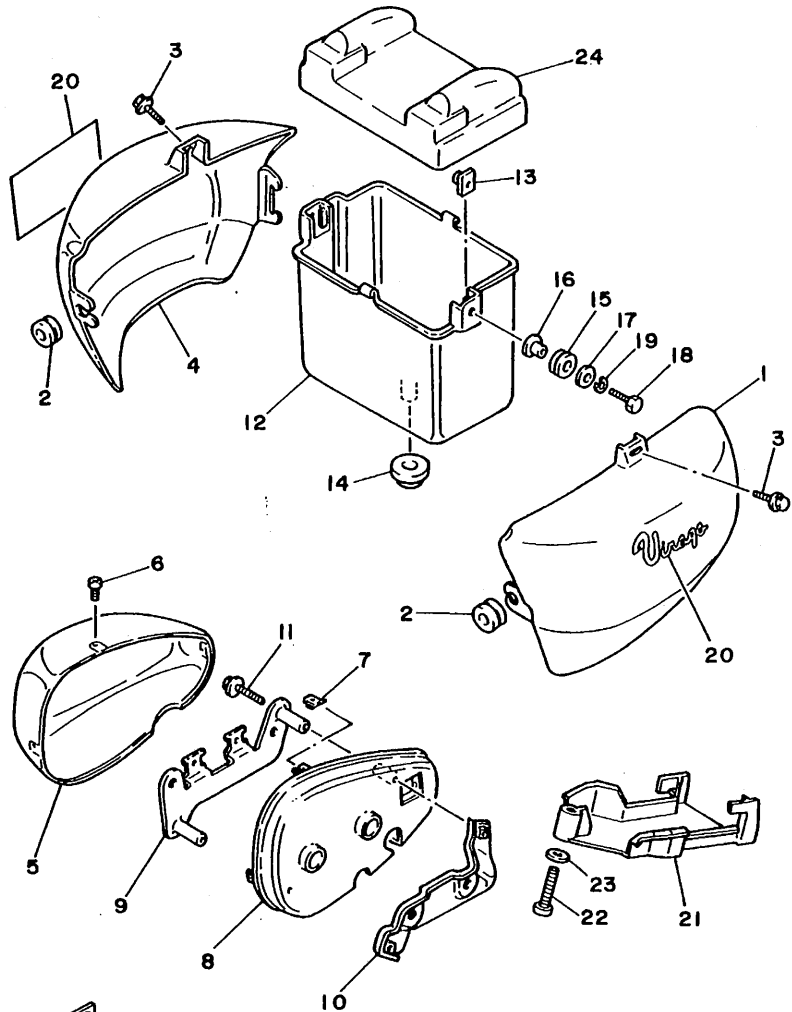

REF. NO.	PART NO.	DESCRIPTION	Q'TY	REMARKS
23	92906-06600	WASHER, plate	1	
24	3JB-28185-00	LID	1	

38T3351-9210

D2

FIG. 22 REAR ARM. SUSPENSION

REF. NO.	PART NO.	DESCRIPTION	Q'TY	REMARKS
1	2GV-22110-00-35	REAR ARM COMP.	1	SILVER
2	93320-32403	BEARING	2	
3	4X7-22124-00	BUSH 2	1	
4	4X7-22129-00	COVER, thrust 2	2	
5	90201-244A8	WASHER, plate (1.95T)	2	
6	4X7-22141-00	SHAFT, pivot	1	
7	90215-16181	WASHER, lock	1	
8	22U-22189-00	BOOT, rubber	1	
9	97313-08035	BOLT	1	
10	92990-08100	WASHER, spring	1	
11	2YL-22210-00	SHOCK ABSORBER ASSY, rear	1	
12	2GV-22226-00	.BUSH, shock absorber lower	1	
13	2GV-22253-00	.COLLAR, distance	1	
14	2GV-22216-00	.BUSH, rear shock absorber	1	
15	2YL-22220-00	SHOCK ABSORBER ASSY, rear	1	
16	2GV-22226-00	.BUSH, shock absorber lower	2	
17	5M0-22253-00	.COLLAR, distance	1	
18	95801-08012	BOLT, flange	2	
19	90201-08753	WASHER, plate	2	
20	90201-10437	WASHER, plate	1	
21	90176-10073	NUT, crown	1	
22	92990-10100	WASHER, spring	1	
23	90106-10052	BOLT	1	

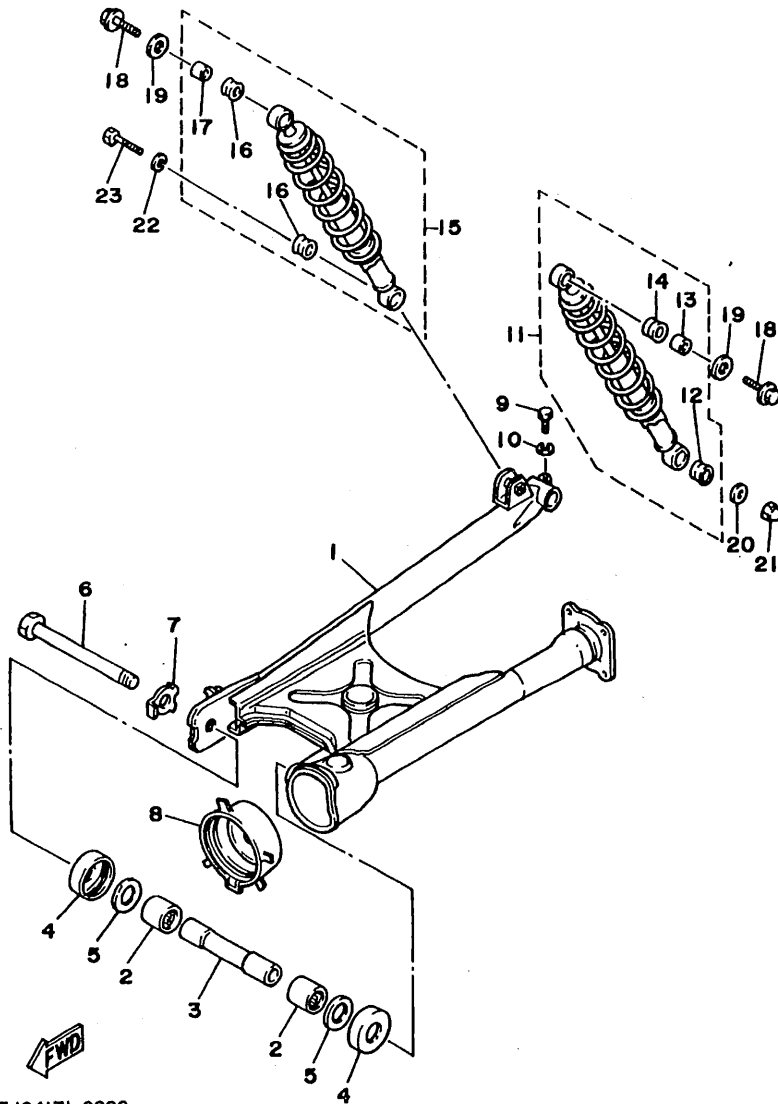

3JC4171-0220

FIG. 23 DRIVE SHAFT

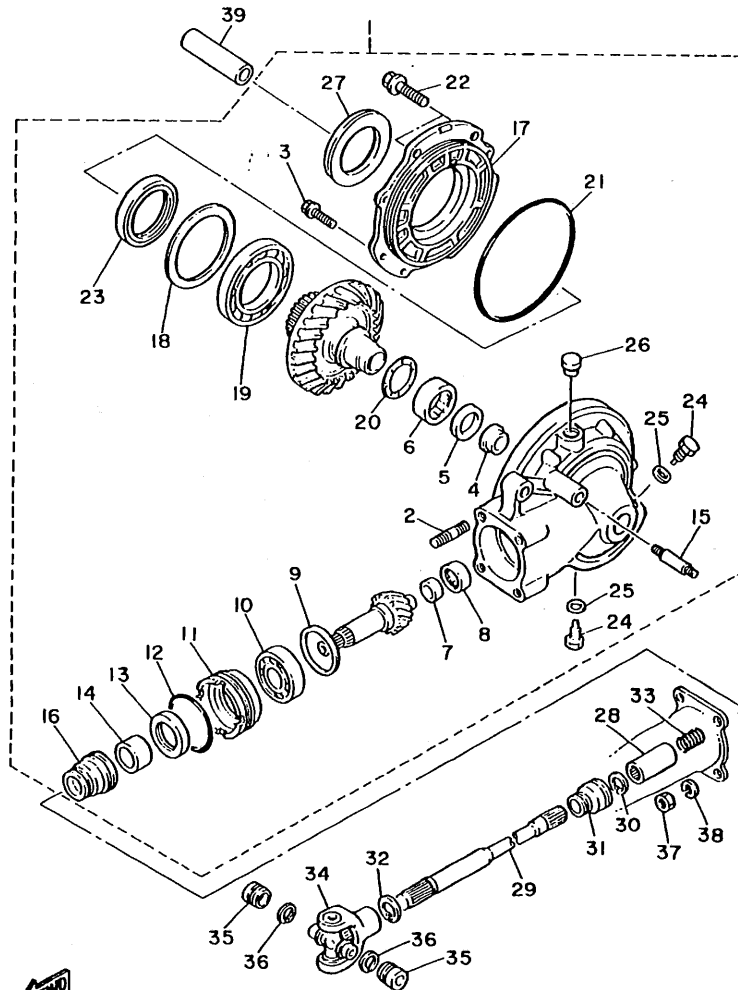

2JV171-7230

REF. NO.	PART NO.	DESCRIPTION	Q'TY	REMARKS
1	2NT-46101-00	REAR AXLE GEAR CASE ASSY	1	
2	90116-10428	.BOLT, stud	4	
3	90119-08126	.BOLT, with washer	6	
4	22U-46153-00	.COLLAR, guide	1	
5	93101-30084	.OIL SEAL	1	
6	93311-43729	.BEARING, cylindrical	1	
7	2H7-46122-00	.RACE, inner	1	
8	93317-41510	.BEARING, cylindrical	1	
9	1J7-17537-Y0-30	.SHIM, thrust (0.30T)	1	UR
	1J7-17537-Y0-40	.SHIM, thrust (0.40T)	1	UR
	1J7-17537-Y0-50	.SHIM, thrust (0.50T)	1	UR
	1J7-17537-Y0-60	.SHIM, thrust (0.60T)	1	UR
10	93306-30539	.BEARING	1	
11	4H7-46125-00	.RETAINER, bearing	1	
12	93210-60426	.O-RING	1	
13	93101-38098	.OIL SEAL	1	
14	90387-25669	.COLLAR	1	
15	90116-10249	.BOLT, stud	1	
16	22U-46136-00	.SEAL 1	1	
17	22U-46152-00	.HOUSING, bearing	1	
18	22U-46117-00-25	.SHIM, ring gear (0.25T)	1	UR
	22U-46117-00-30	.SHIM, ring gear (0.30T)	1	UR
	22U-46117-00-40	.SHIM, ring gear (0.40T)	1	UR
	22U-46117-00-50	.SHIM, ring gear (0.50T)	1	UR
19	93316-01301	.BEARING, cylindrical	1	
20	22U-46118-00-12	.SHIM, thrust (1.2T)	1	UR
	22U-46118-00-14	.SHIM, thrust (1.4T)	1	UR
	22U-46118-00-16	.SHIM, thrust (1.6T)	1	UR

D4

FIG. 23 DRIVE SHAFT

REF. NO.	PART NO.	DESCRIPTION	Q'TY	REMARKS
20	22U-46118-00-18	.SHIM, thrust (1.8T)	1	UR
	22U-46118-00-20	.SHIM, thrust (2.0T)	1	UR
21	93211-39569	.O-RING	1	
22	90105-10285	.BOLT, washer based	2	
23	93102-65277	.OIL SEAL	1	
24	11H-13455-00	.PLUG	2	
25	214-11198-01	.GASKET	2	
26	2H7-17590-00	.BREATHER COMP.	1	
27	1J7-25319-01	.SEAL, hub dust	1	
28	22U-46123-00	COUPLING, gear	1	
29	2GV-46172-00	SHAFT, drive	1	
30	93440-19112	CIRCLIP	1	
31	22U-46137-00	SEAL 2	1	
32	93410-22039	CIRCLIP	1	
33	90501-15722	SPRING, compression	1	
34	4X7-46180-00	CROSS JOINT COMP.	1	
35	93399-99926	BEARING	2	
36	93440-20088	CIRCLIP	2	
37	95311-10600	NUT	4	
38	92901-10100	WASHER, spring	4	
39	90387-15668	COLLAR	1	

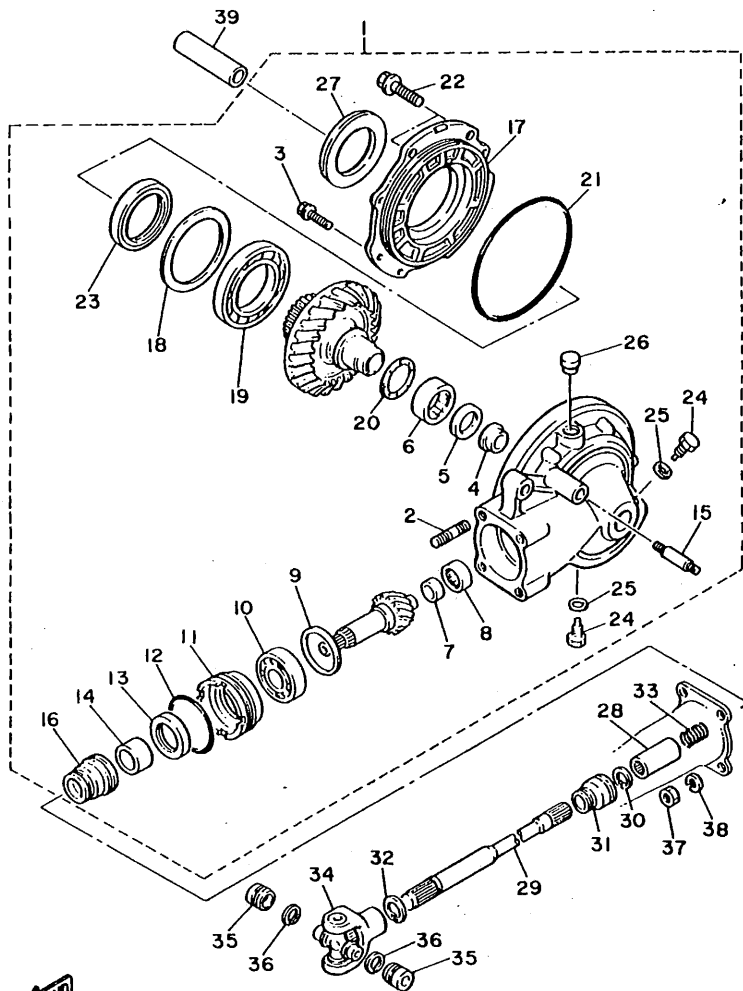

FWD

2JV171-7230

D5

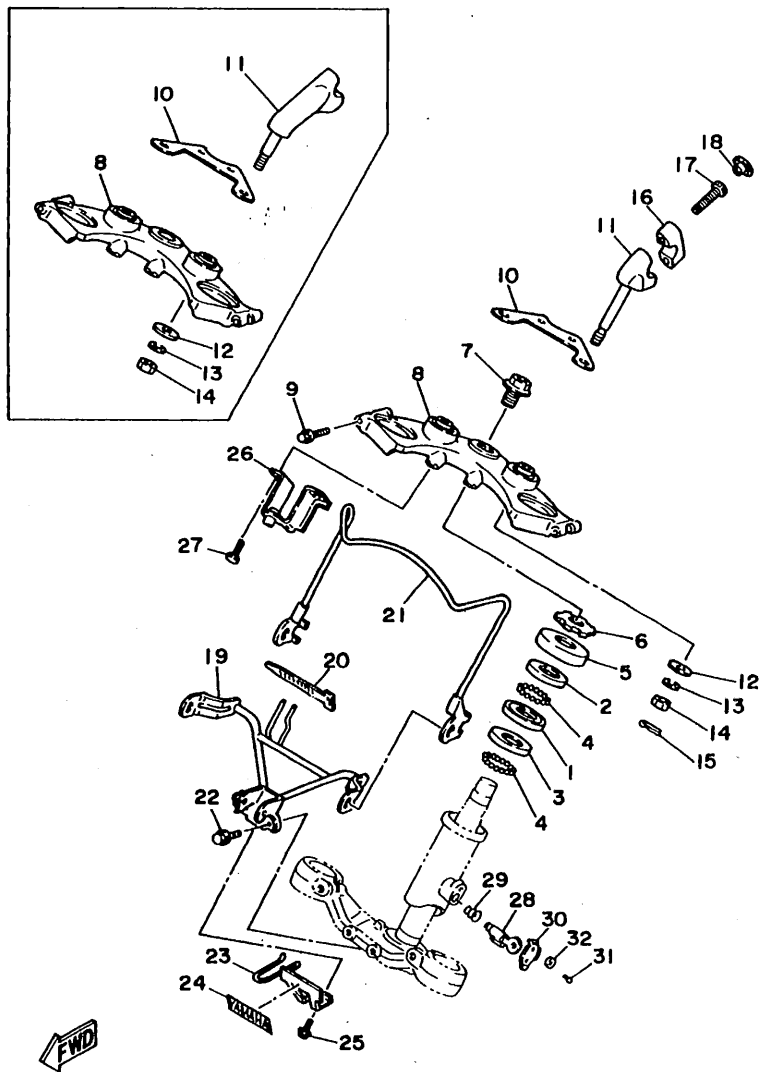

3BTC300-0240

FIG. 24 STEERING

REF. NO.	PART NO.	DESCRIPTION	Q'TY	REMARKS
1	156-23412-00	RACE, ball 2	1	
2	183-23411-00	RACE, ball 1	1	
3	183-23412-00	RACE, ball 2	1	
4	93501-04011	BALL	38	
5	4K0-23415-00	COVER, ball race 1	1	
6	90179-25033	NUT	1	
7	90105-14102	BOLT, washer based	1	
8	3JB-W2341-00-38	CROWN, handle	1	UR FOR FLAT HANDLE
	2GV-W2341-00-38	CROWN, handle	1	UR FOR UP HANDLE
9	90105-08698	BOLT, washer based	2	
10	3JB-2317F-00	STAY 2	1	UR FOR FLAT HANDLE
	2GV-2317F-00	STAY 2	1	UR FOR UP HANDLE
11	3AL-23442-00-38	HOLDER, handle lower	2	UR CLEAR (WITH BUFF) FOR FLAT HANDLE
	42X-23442-00-38	HOLDER, handle lower	2	UR CLEAR (WITH BUFF) FOR UP HANDLE
12	92901-12200	WASHER, plain	2	UR FOR FLAT HANDLE
	90201-100A1	WASHER, plate	2	UR FOR UP HANDLE
13	92901-12100	WASHER, spring	2	UR FOR FLAT HANDLE
	90201-10100	WASHER, spring	2	UR FOR UP HANDLE
14	95311-12700	NUT	2	UR FOR FLAT HANDLE
	95303-10700	NUT	2	UR FOR UP HANDLE
15	90468-12006	CLIP	2	
16	4H7-23441-00-38	HOLDER, handle upper	2	CLEAR (WITH BUFF)
17	91311-08030	BOLT	4	
18	90338-08163	PLUG	4	
19	2GV-23174-00	STAY, headlight	1	
20	3TB-83936-00	BAND, switch cord	1	
21	2NT-23164-00	STAY, light guard	1	
22	95023-06020	BOLT	2	

D6

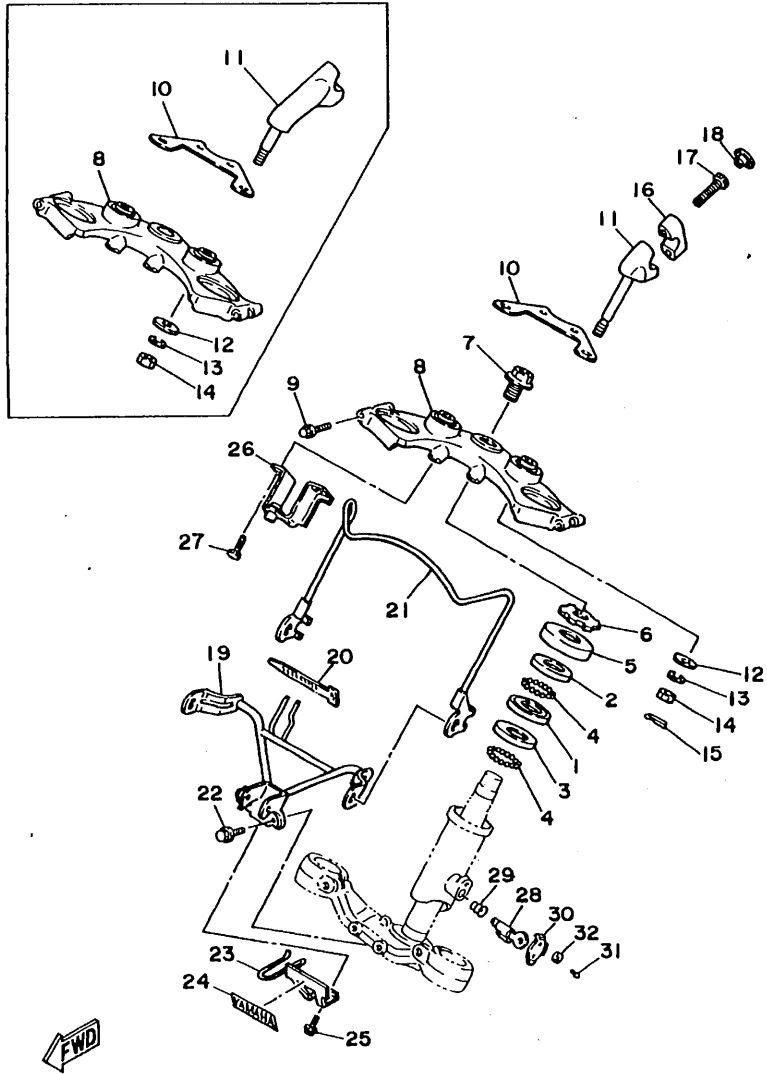
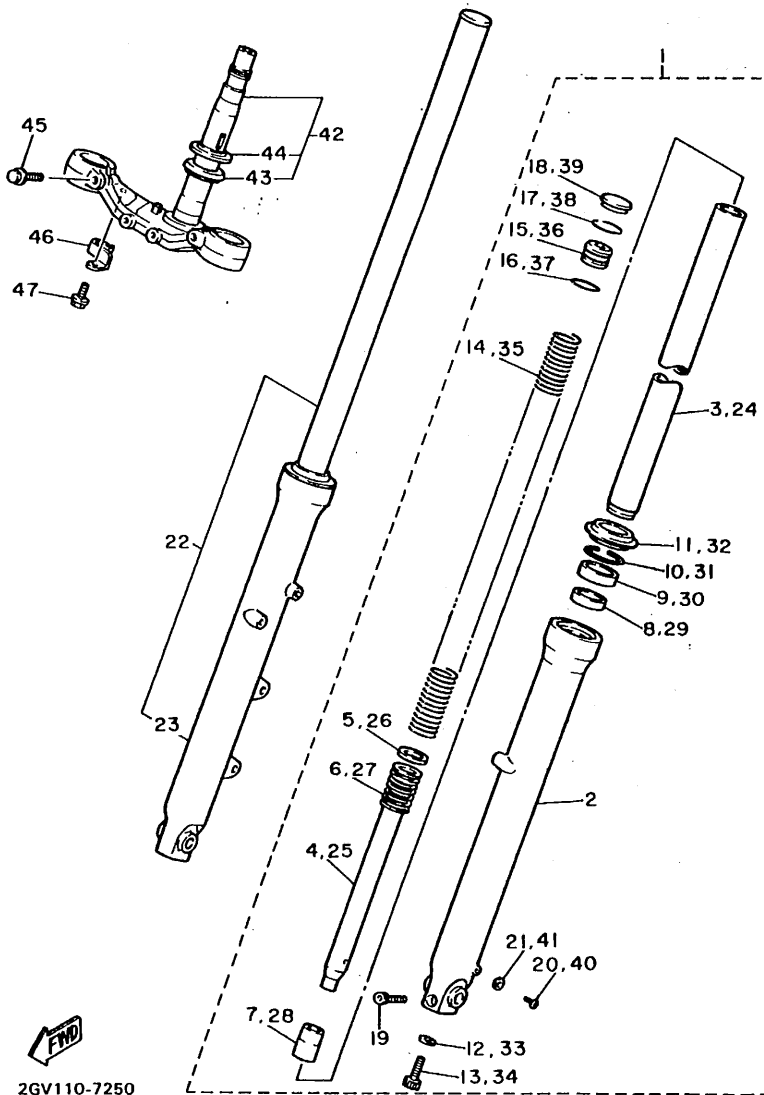

FIG. 24 STEERING

REF. NO.	PART NO.	DESCRIPTION	Q'TY	REMARKS
23	2GV-2317M-00	STAY 3	1	
24	3AA-21578-21	EMBLEM	1	
25	95023-06008	BOLT	1	
26	2GV-2317E-00	STAY	1	
27	91316-06016	BOLT	2	
28	2A6-23408-00	STEERING LOCK ASSY	1	
29	90502-09024	SPRING, conical	1	
30	3DM-23484-00	CAP, handle lock	1	
31	90269-04003	RIVET	1	
32	90208-04029	WASHER, conical spring	1	

3BTC300-0240

D7



2GV110-7250

FIG. 25 FRONT FORK

REF. NO.	PART NO.	DESCRIPTION	Q'TY	REMARKS
1	2NT-23102-01	FRONT FORK ASSY (L.H)	1	
2	2NT-23126-01	.TUBE, outer 1	1	
3	2GV-23110-00-93	.INNER TUBE COMP.1	1	CHROME PLATED
4	2GV-23171-00	.PISTON, front fork	1	
5	1GU-23157-00	.RING, piston	1	
6	1GU-23151-00	.SPRING, rebound	1	
7	1GU-23173-00	.SPINDLE, taper	1	
8	2GV-23125-00	.METAL, slide 1	1	
9	2AJ-23145-00	.OIL SEAL	1	
10	1HX-23156-00	.CLIP, oil seal	1	
11	2GV-23144-00	.SEAL, dust	1	
12	90430-08155	.GASKET	1	
13	91311-08025	.BOLT	1	
14	2GV-23141-00	.SPRING, front fork	1	
15	1HX-23111-00	.BOLT, cap	1	
16	93210-24709	.O-RING	1	
17	93450-32116	.CIRCLIP	1	
18	1HX-23154-00	.PLUG, inner tube	1	
19	90110-08110	.BOLT, hexagon socket head	1	
20	98501-04006	.SCREW, pan head	1	
21	5U8-23129-00	.GASKET, drain plug	1	
22	2NT-23103-01	FRONT FORK ASSY (R.H)	1	
23	2NT-23136-01	.TUBE, outer 2	1	
24	2GV-23110-00-93	.INNER TUBE COMP.1	1	CHROME PLATED
25	2GV-23171-00	.PISTON, front fork	1	
26	1GU-23157-00	.RING, piston	1	
27	1GU-23151-00	.SPRING, rebound	1	
28	1GU-23173-00	.SPINDLE, taper	1	

D8

FIG. 25 FRONT FORK

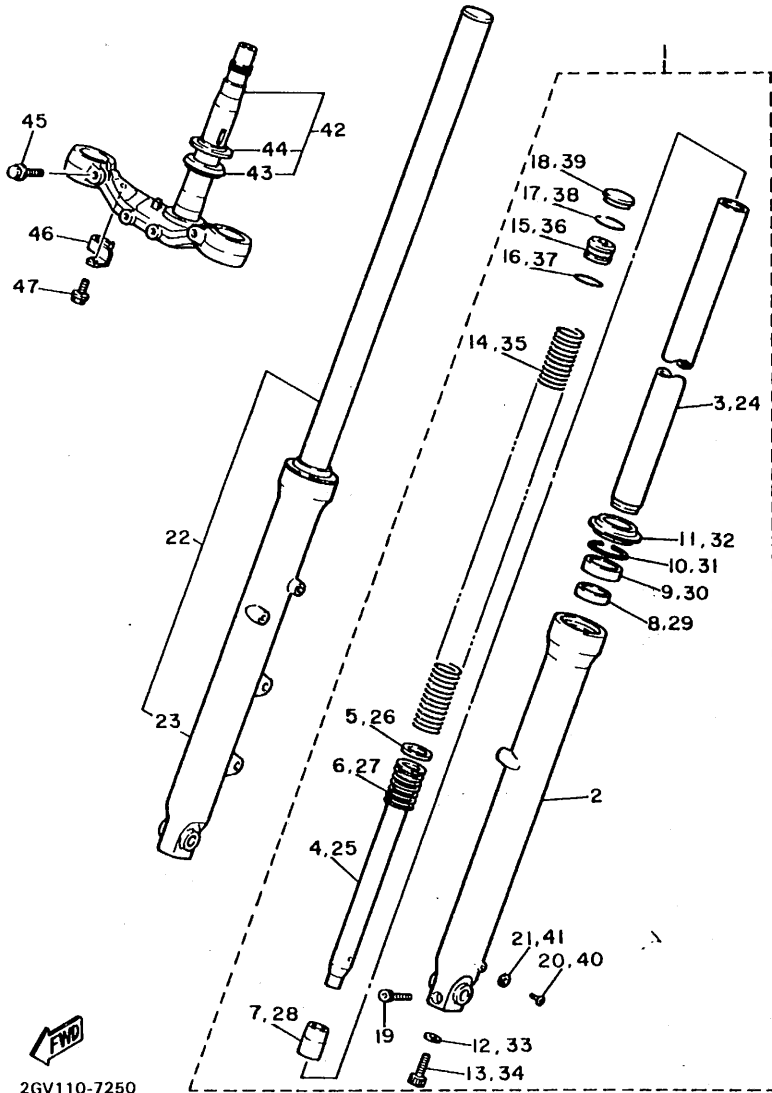

REF. NO.	PART NO.	DESCRIPTION	Q'TY	REMARKS
29	2GV-23125-00	.METAL, slide 1	1	
30	2AJ-23145-00	.OIL SEAL	1	
31	1HX-23156-00	.CLIP, oil seal	1	
32	2GV-23144-00	.SEAL, dust	1	
33	90430-08155	.GASKET	1	
34	91311-08025	.BOLT	1	
35	2GV-23141-00	.SPRING, front fork	1	
36	1HX-23111-00	.BOLT, cap	1	
37	93210-24709	.O-RING	1	
38	93450-32116	.CIRCLIP	1	
39	1HX-23154-00	.PLUG, inner tube	1	
40	98501-04006	.SCREW, pan head	1	
41	5U8-23129-00	.GASKET, drain plug	1	
42	3BR-23340-00	UNDER BRACKET COMP.	1	
43	164-23462-00	.SEAL, steering	1	
44	156-23411-00	.RACE, ball 1	1	
45	95821-12035	BOLT, flange	2	
46	2GV-25886-00	HOLDER, brake hose	1	
47	95826-06010	BOLT, flange	1	

FWD

2GV110-7250

D9

FIG. 26 FUEL TANK

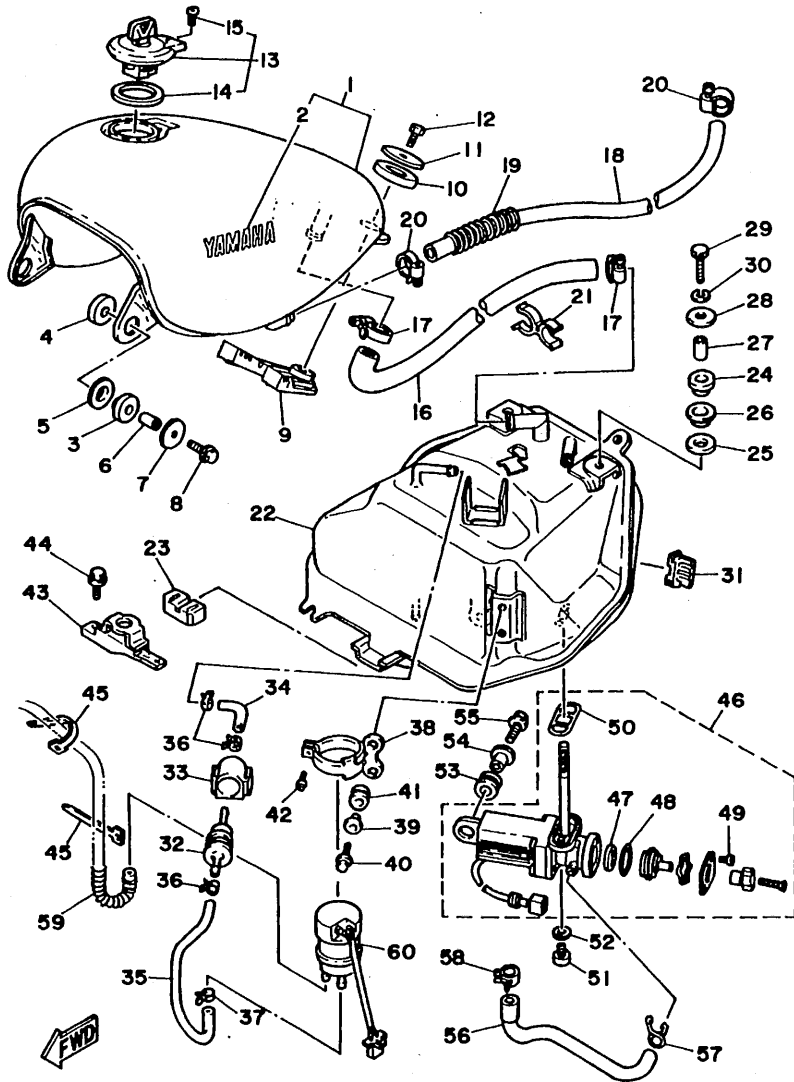

38T3351-9260

REF. NO.	PART NO.	DESCRIPTION	Q'TY.	REMARKS
1	3BR-Y2428-20-PO	SUB TANK ASSY	1	UR LIGHT GRAYISH BLUE METALLIC 1
	3BR-Y2428-30-RO	SUB TANK ASSY	1	UR GRACEFUL MAROON
	3BR-Y2428-30-4B	SUB TANK ASSY	1	UR BLACK 2
2	99225-00100	.EMBLEM, yamaha	2	UR FOR GRM, BL2
	99224-00100	.EMBLEM, yamaha	2	UR FOR LGBM1
3	1FK-24182-00	DAMPER, locating 2	2	
4	23T-24724-01	DAMPER, seat	2	
5	1FK-24186-00	WASHER, special	2	
6	90387-06387	COLLAR	2	
7	90201-066M2	WASHER, plate	2	
8	90105-06700	BOLT, washer based	2	
9	3JB-24182-00	DAMPER, locating 2	1	
10	42X-24183-00	DAMPER, locating 3	1	
11	90201-08569	WASHER, plate	1	
12	97313-08016	BOLT	1	
13	4X7-24602-02	CAP ASSY	1	
14	4X7-24612-00	.GASKET, cap	1	
15	91311-05010	.BOLT	1	
16	3JB-24316-00	PIPE 6	1	
17	90450-25037	HOSE CLAMP ASSY	2	
18	3JB-24317-00	PIPE 7	1	
19	90501-101J4	SPRING, compression	1	
20	90450-22017	HOSE CLAMP ASSY	2	
21	3JB-24135-00	CLAMP 1	1	
22	3JB-24110-01-33	FUEL TANK COMP.	1	YAMAHA BLACK
23	2GV-24181-00	DAMPER, locating 1	1	
24	1FK-24182-00	DAMPER, locating 2	2	
25	23T-24724-01	DAMPER, seat	2	

FIG. 26 FUEL TANK

REF. NO.	PART NO.	DESCRIPTION	Q'TY	REMARKS
26	1FK-24186-00	WASHER, special	2	
27	90387-06387	COLLAR	2	
28	90201-065G8	WASHER, plate	2	
29	97026-06030	BOLT	2	
30	92906-06100	WASHER, spring	2	
31	2GV-24184-00	DAMPER, locating 4	2	
32	1FK-24560-00	FILTER ASSY	1	
33	1FK-24566-00	BRACKET, filter	1	
34	2GV-24311-00	PIPE, fuel 1	1	
35	2GV-24312-00	PIPE 2	1	
36	90467-11044	CLIP	3	
37	90467-10135	CLIP	1	
38	2GV-24491-00	BRACKET, fuel pump	1	
39	90387-062L2	COLLAR	2	
40	95816-06016	BOLT, flange	2	
41	90480-13163	GROMMET	2	
42	98506-05016	SCREW, pan head	1	
43	2GV-24191-00	BRACKET, fuel tank 1	1	
44	90119-06123	BOLT, with washer	2	
45	437-83936-11	BAND, switch cord	3	
46	3JB-24500-02	FUEL COCK ASSY 1	1	
47	3AJ-24523-00	.VALVE	1	
48	3AJ-24534-00	.SEAL, cock	1	
49	98503-03008	.SCREW, pan head	2	
50	4X8-24512-00	.O-RING	1	
51	90149-06008	SCREW	2	
52	90202-05193	WASHER, plate	2	
53	90480-14023	GROMMET	1	

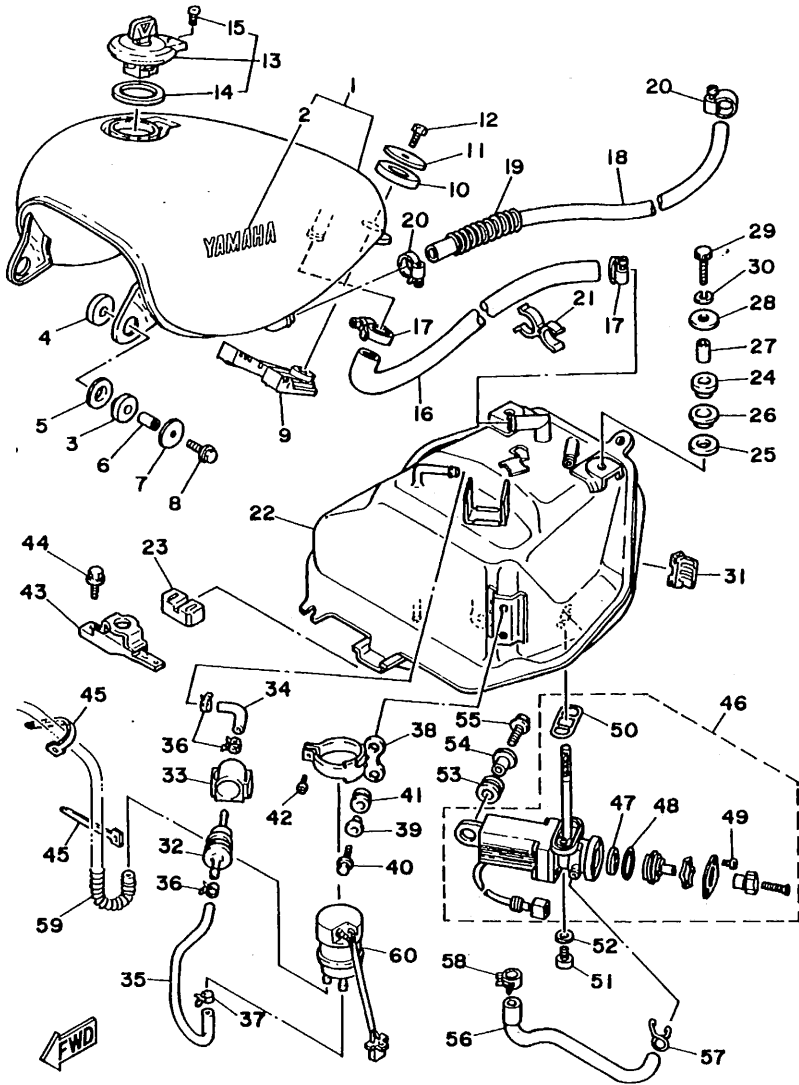

3BT3351-9260

FIG. 26 FUEL TANK

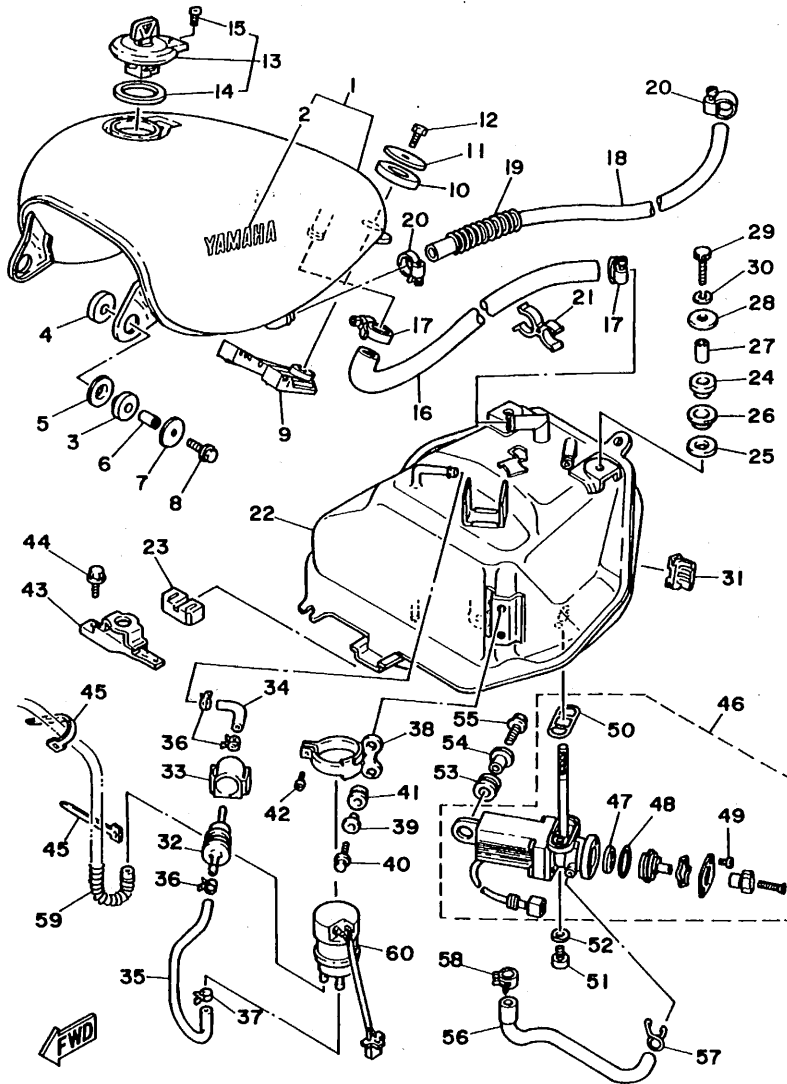

REF. NO.	PART NO.	DESCRIPTION	Q'TY	REMARKS
54	90387-06388	COLLAR	1	
55	95816-06025	BOLT, flange	1	
56	3JB-24314-00	PIPE 4	1	
57	90467-10008	CLIP	1	
58	90467-11044	CLIP	1	
59	90501-100F8	SPRING, compression	1	
60	1HX-13907-00	FUEL PUMP COMP.	1	

3BT3351-9260

D12

FIG. 27 SEAT

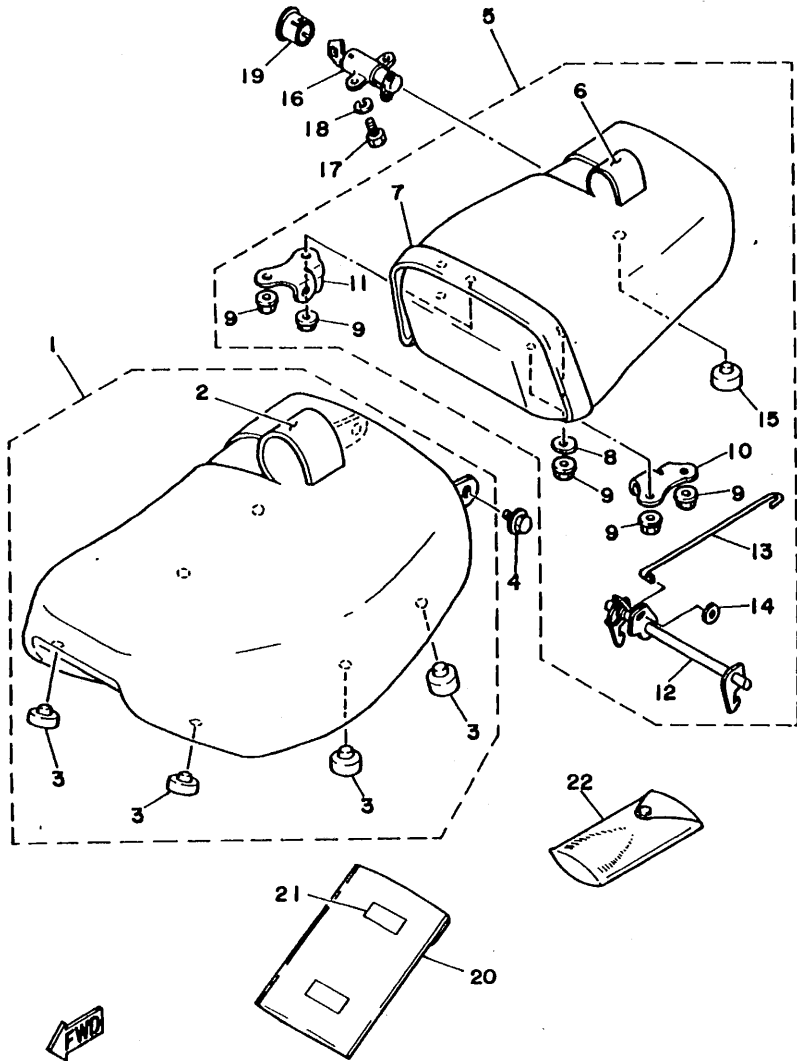

REF. NO.	PART NO.	DESCRIPTION	Q'TY	REMARKS
1	3JB-24710-00	SINGLE SEAT ASSY	1	
2	3JB-24711-00	.COVER, single seat	1	
3	18A-24724-00	.DAMPER, seat	6	
4	90119-06114	BOLT, with washer	2	
5	3JB-24750-00	TANDEM SEAT ASSY	1	
6	3JB-24751-00	.COVER, tandem seat	1	
7	3JB-24754-00	.HOOK, seat	1	
8	90201-06067	.WASHER, plate	2	
9	95701-06500	.NUT, flange	6	
10	3JB-24718-00	.BRACKET, seat	1	
11	3JB-24728-00	.BRACKET, seat	1	
12	3JB-24776-00	.LEVER, seat	1	
13	3JB-2478F-00	.ROD, connecting	1	
14	92990-03200	.WASHER, plain	1	
15	18A-24724-00	.DAMPER, seat	1	
16	51X-24705-00	SEAT LOCK ASSY	1	
17	97003-06014	BOLT	2	
18	92990-06100	WASHER, spring	2	
19	51Y-24796-00	COVER	1	
20	4K5-28186-00	POUCH	1	
21	4K5-2814E-10	HOOK	2	
22	2GV-28100-00	TOOL KIT	1	

3JB5010-2270

D13

FIG. 28 FRONT WHEEL

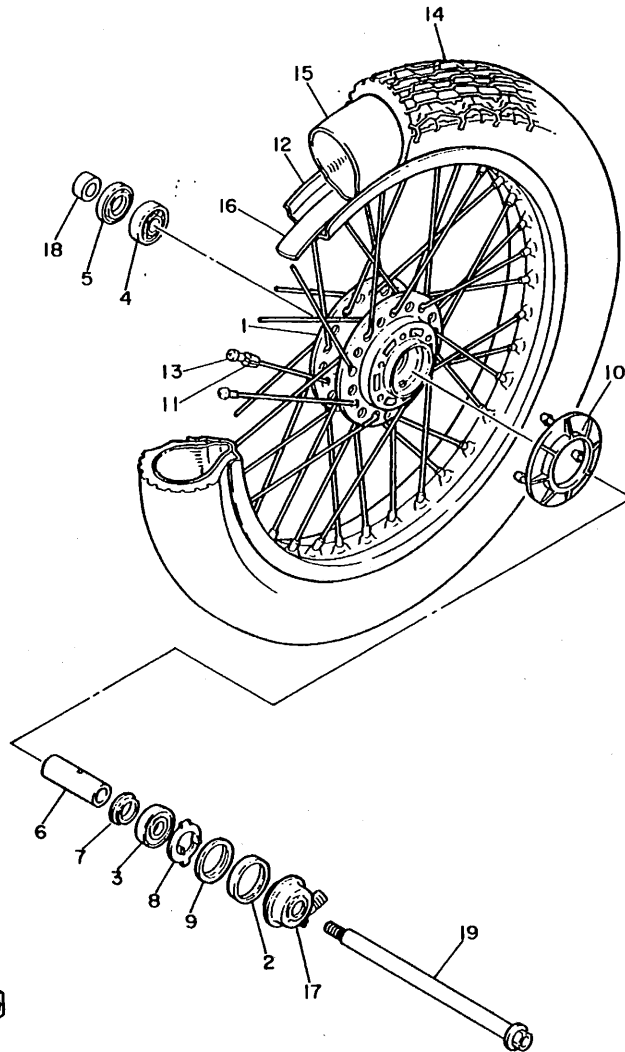

2GV110-7280

REF. NO.	PART NO.	DESCRIPTION	Q'TY	REMARKS
1	341-25111-01-35	HUB, front	1	SILVER
2	93105-45017	OIL SEAL	1	
3	93306-30309	BEARING (B6303ZZ)	1	
4	93306-30309	BEARING (B6303ZZ)	1	
5	93102-28022	OIL SEAL	1	
6	90560-17126	SPACER	1	
7	146-25315-00	FLANGE, spacer	1	
8	341-25149-00	CLUTCH, meter	1	
9	341-25846-00	RETAINER, clutch	1	
10	1L9-25847-00	COVER, housing	1	
11	156-25398-00	BALANCER, wheel	1	
12	94418-19443	RIM (1.85-19)	1	
13	2GV-25104-00	SPOKE SET, front	1	
14	94130-197N1	TIRE (3.00S19 4PR L303A T/T)	1	UR BRIDGESTONE
	94130-197N0	TIRE (300S19 4PR F14GDOTN)	1	UR DUNLOP
15	94227-19177	TUBE (2.75-19)	1	DUNLOP
16	94335-19026	BAND, rim (3.50-19)	1	UR BRIDGESTONE
	94325-19115	BAND, rim (2.50-19)	1	UR DUNLOP
17	1FK-25190-00	GEAR UNIT ASSY	1	
18	90387-177R1	COLLAR	1	
19	2GV-25181-00	AXLE, wheel	1	

FIG. 29 FRONT BRAKE CALIPER

REF. NO.	PART NO.	DESCRIPTION	Q'TY	REMARKS
1	3JB-25831-00	DISC, brake (RIGHT)	1	
2	90101-08312	BOLT	6	
3	1J3-25834-01	WASHER, lock	3	
4	3JB-2580U-00	CALIPER ASSY (RIGHT)	1	
5	2GV-W0057-00	.PISTON ASSY, caliper	1	
6	2GV-W0047-00	..CALIPER SEAL KIT	1	
7	5R2-25937-00	.BOOT 2	1	
8	34X-25937-00	.BOOT 2	1	
9	51L-W0048-00	.BREED SCREW KIT	1	
10	2GV-25919-00	.SUPPORT, pad	2	
11	3JB-W0045-00	.BRAKE PAD KIT	1	
12	34X-25926-00	.BOLT	1	
13	34X-25845-00	.CAP, indicator	1	
14	3JB-25827-00	.SHIM, caliper	1	
15	90105-10638	BOLT, washer based	2	

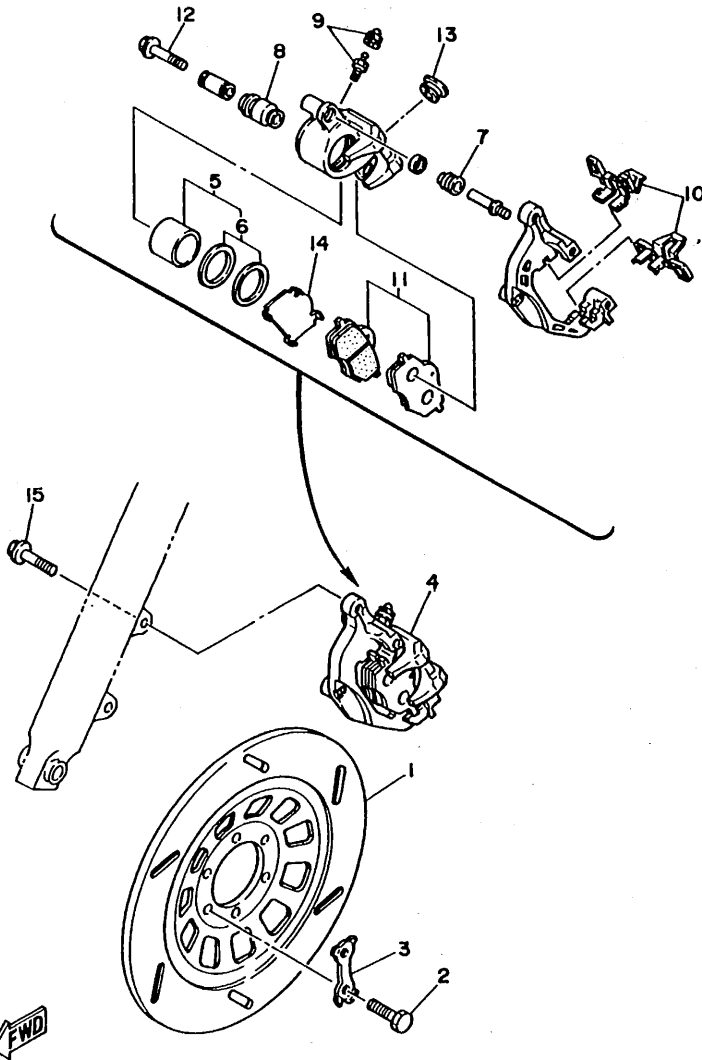

38T3351-9290

D15

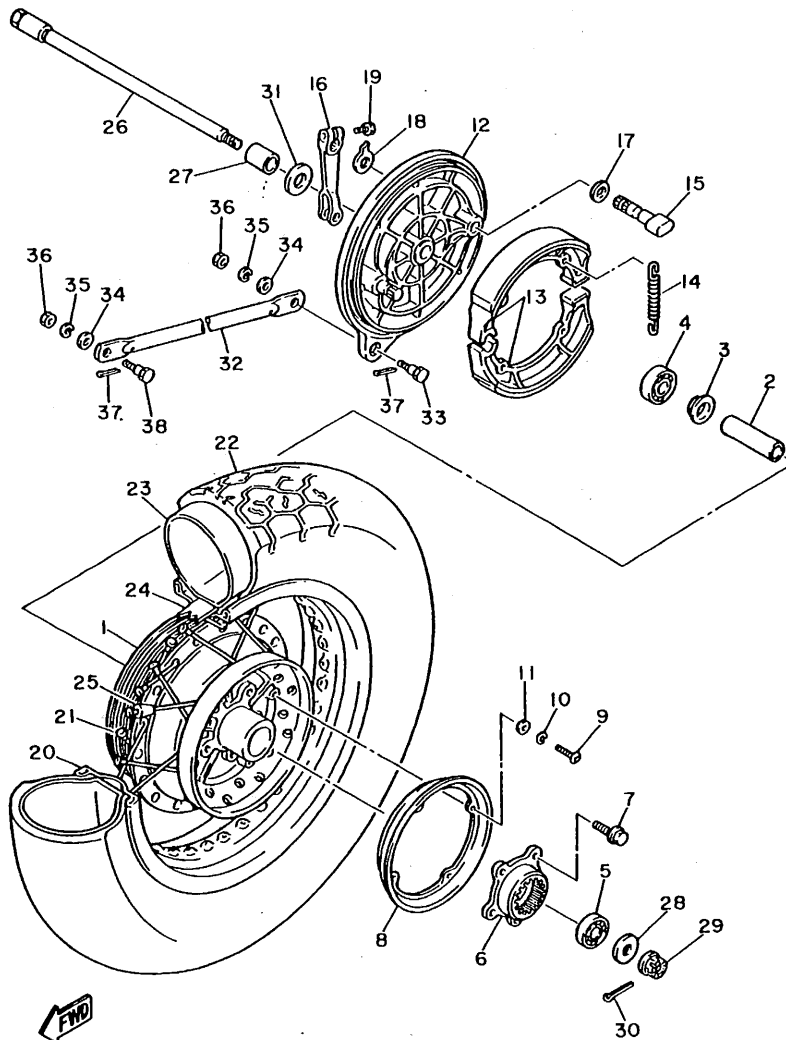

2GV110-7300

FIG. 30 REAR WHEEL

REF. NO.	PART NO.	DESCRIPTION	Q'TY	REMARKS
1	2GV-25311-00-35	HUB, rear	1	SILVER
2	2GV-25317-00	SPACER, bearing	1	
3	146-25115-00	FLANGE, spacer 1	1	
4	93306-30209	BEARING	1	
5	93306-30203	BEARING (B6302Z)	1	
6	2GV-25366-00	CLUTCH, hub	1	
7	90105-10200	BOLT, washer based	5	
8	2GV-25319-00	SEAL, hub dust	1	
9	98501-05012	SCREW, pan head	4	
10	92901-05100	WASHER, spring	4	
11	92901-05600	WASHER, plate	4	
12	2NT-25321-00	PLATE, brake shoe	1	
13	3DR-W2536-00	BRAKE SHOE SET	1	
14	90507-20002	SPRING, tension	2	
15	4H7-25351-00	CAMSHAFT	1	
16	214-25355-00	LEVER, camshaft	1	
17	90201-14218	WASHER, plate	1	
18	4H7-2533A-02	PLATE, indicator	1	
19	90101-06291	BOLT	1	
20	94430-15477	RIM	1	
21	2GV-25304-00	SPOKE SET, rear	1	
22	94114-156U2	TIRE (140/90-15M/C70SK425)	1	UR BRIDGESTONE
	94114-156U1	TIRE (140/90-15M/C70SK425)	1	UR DUNLOP
23	94214-15223	TUBE (140-15)	1	UR BRIDGESTONE
	94214-15225	TUBE (140/90-15)	1	UR DUNLOP
24	94330-15134	BAND, rim (3.00-15)	1	BRIDGESTONE
25	156-25398-00	BALANCER, wheel	1	
26	2GV-25381-00	AXLE, wheel	1	

E2

FIG. 30 REAR WHEEL

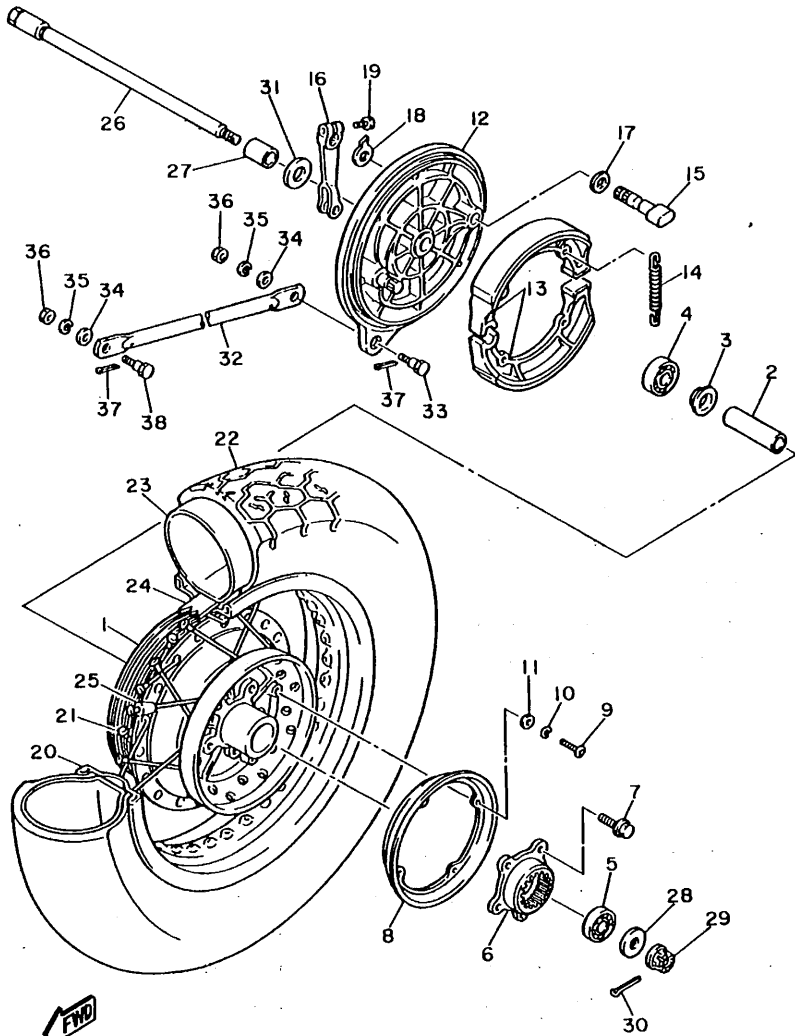

REF. NO.	PART NO.	DESCRIPTION	Q'TY	REMARKS
27	90387-157R0	COLLAR	1	
28	90201-144J5	WASHER, plate	1	
29	90171-14031	NUT, castle	1	
30	91401-30030	PIN, cotter	1	
31	22U-25377-00	COLLAR, wheel	1	
32	42X-25371-00	BAR, tension	1	
33	90109-08406	BOLT	1	
34	92901-08600	WASHER, plate	2	
35	92990-08100	WASHER, spring	2	
36	95303-08700	NUT	2	
37	91401-20015	PIN, cotter	2	
38	90109-08368	BOLT	1	

FWD

2GV110-7300

E3

FIG. 31 STEERING HANDLE. CABLE (FLAT HANDLE)

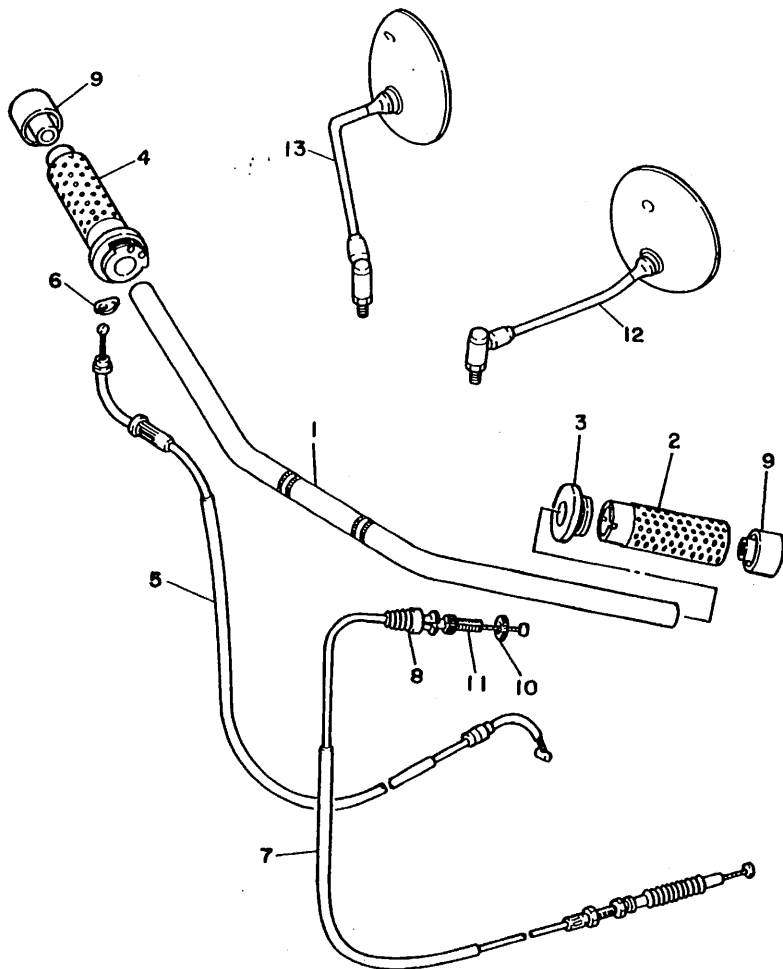

REF. NO.	PART NO.	DESCRIPTION	Q'TY	REMARKS
1	2NT-26111-10	HANDLEBAR	1	
2	3JB-26241-00	GRIP (LEFT)	1	
3	3JB-26273-00	ROTOR	1	
4	3JB-26240-00	GRIP ASSY	1	
5	2GV-26311-00	CABLE, throttle 1	1	
6	5HO-26393-00	HOLDER	1	
7	3JB-26335-00	CABLE, clutch	1	
8	1E6-26342-00	BOOT, cable	1	
9	3JB-2628J-00	CAP, grip	2	
10	90179-08148	NUT	1	
11	90123-08046	BOLT	1	
12	1J7-26290-F0	BACK MIRROR ASSY (LEFT)	1	
13	1J7-26290-G0	BACK MIRROR AASY (RIGHT)	1	



3BTA351-0310

E4

FIG. 32 STEERING HANDLE. CABLE (UP HANDLE)

REF. NO.	PART NO.	DESCRIPTION	Q'TY	REMARKS
1	2GV-26111-10	HANDLEBAR	1	
2	3JB-26241-00	GRIP (LEFT)	1	
3	3JB-26273-00	ROTOR	1	
4	3JB-26240-00	GRIP ASSY	1	
5	2NU-26311-00	CABLE, throttle 1	1	
6	5HO-26393-00	HOLDER	1	
7	55U-26335-01	CABLE, clutch	1	
8	1E6-26342-00	BOOT, cable	1	
9	3JB-2628J-00	CAP, grip	2	
10	90179-08148	NUT	1	
11	90123-08046	BOLT	1	
12	1J7-26290-F0	BACK MIRROR ASSY (LEFT)	1	
13	1J7-26290-G0	BACK MIRROR AASY (RIGHT)	1	

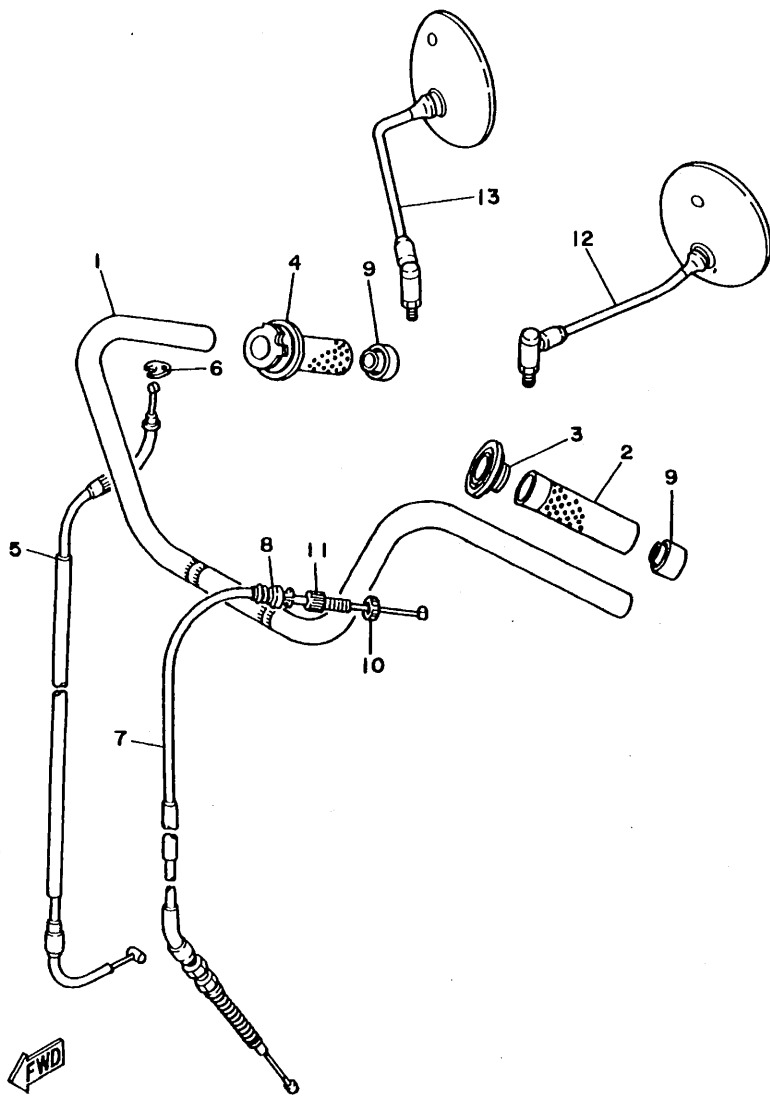

3BT8332-0310

E5

FIG. 33 FRONT MASTER CYLINDER (FLAT HANDLE)

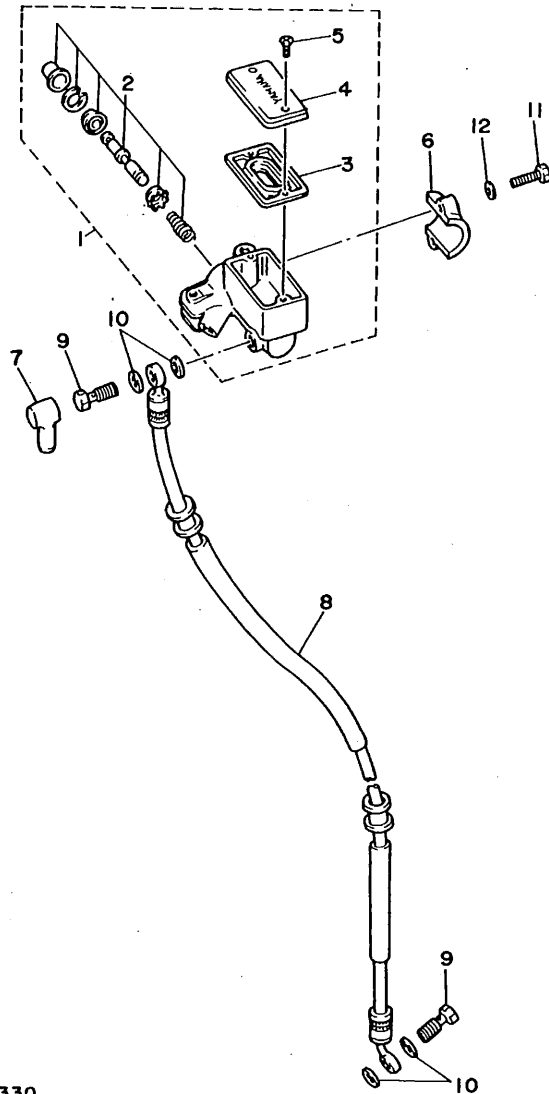

REF. NO.	PART NO.	DESCRIPTION	Q'TY	REMARKS
1	2GV-25850-01	MASTER CYLINDER ASSY	1	
2	4H7-W0041-00	.CYLINDER KIT, master	1	
3	4K0-25854-00	.DIAPHRAGM, reservoir	1	
4	3GM-25852-01	.CAP, reservoir	1	
5	98706-04012	.SCREW, flat head	2	
6	4L0-25867-00	BRACKET, master cylinder	1	
7	4L0-25862-00	BOOT, master cylinder	1	
8	3JB-25872-01	HOSE, brake 1	1	
9	90401-10096	BOLT, union	2	
10	90201-10118	WASHER, plate	4	
11	97016-06025	BOLT	2	
12	92906-06100	WASHER, spring	2	



3BT3351-9330

E6

FIG. 34 FRONT MASTER CYLINDER (UP HANDLE)

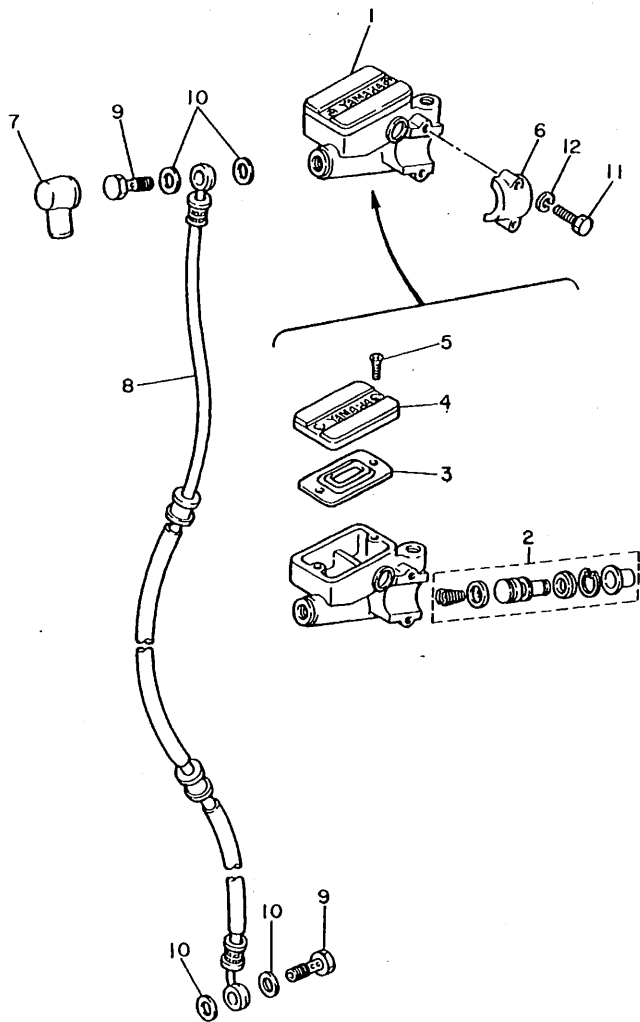

REF. NO.	PART NO.	DESCRIPTION	Q'TY	REMARKS
1	4H7-25850-02	MASTER CYLINDER ASSY	1	
2	4H7-W0041-00	.CYLINDER KIT, master	1	
3	4L0-25854-00	.DIAPHRAGM, reservoir	1	
4	4H7-25852-00	.CAP, reservoir	1	
5	98706-04012	.SCREW, flat head	2	
6	4L0-25867-00	BRACKET, master cylinder	1	
7	4L0-25862-00	BOOT, master cylinder	1	
8	2GV-25872-01	HOSE, brake 1	1	
9	90401-10096	BOLT, union	2	
10	90201-10118	WASHER, plate	4	
11	97016-06025	BOLT	2	
12	92906-06100	WASHER, spring	2	



2NT010-7340

E7

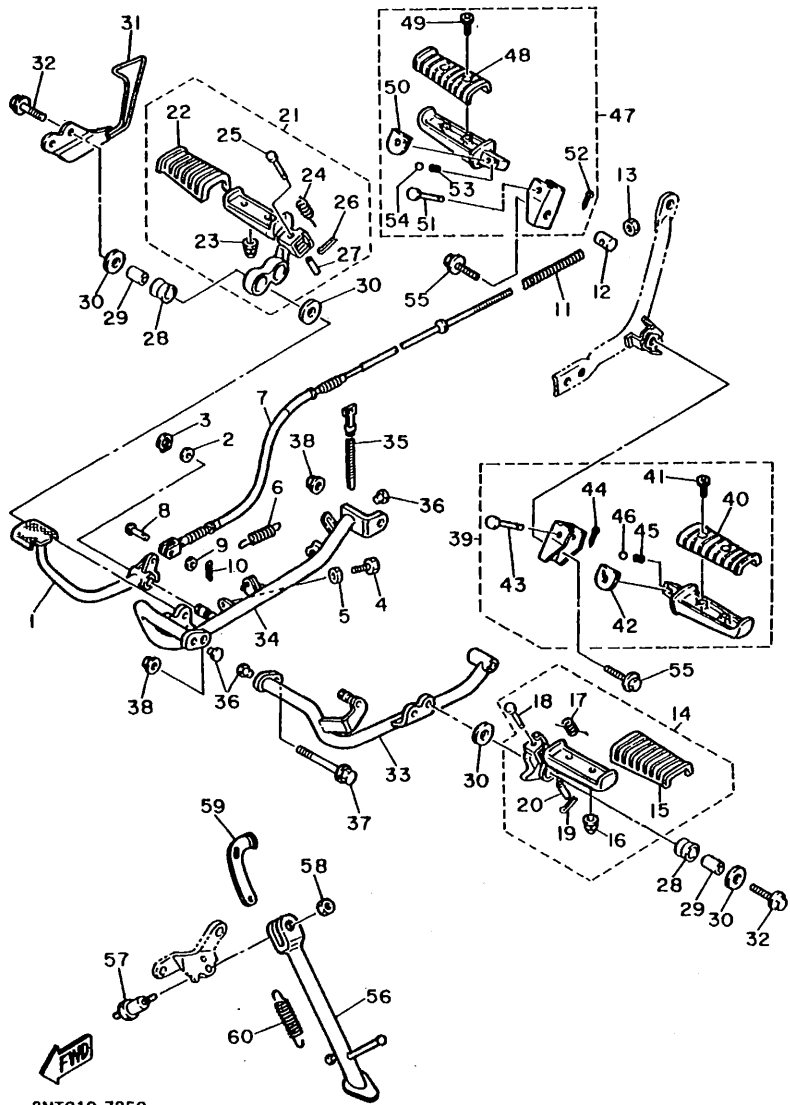

2NT010-7350

FIG. 35 STAND. FOOTREST

REF. NO.	PART NO.	DESCRIPTION	Q'TY	REMARKS
1	2GV-27211-00-93	PEDAL, brake	1	CHROME PLATED
2	90201-152L1	WASHER, plate	1	
3	99009-15400	CIRCLIP	1	
4	90101-06288	BOLT	1	
5	95303-06600	NUT	1	
6	90506-20380	SPRING, tension	1	
7	2GV-26351-00	CABLE, brake	1	
8	91701-06022	PIN, clevis	1	
9	92901-06200	WASHER, plain	1	
10	91401-20015	PIN, cotter	1	
11	90501-10245	SPRING, compression	1	
12	90249-12008	PIN	1	
13	90179-06176	NUT	1	
14	1RM-27410-00-93	FRONT FOOTREST ASSY (LEFT)	1	CHROME PLATED
15	1NH-27413-00	.COVER, footrest	1	
16	90176-06058	.NUT, crown	2	
17	90508-18696	.SPRING, torsion	1	
18	91701-08038	.PIN, clevis	1	
19	91401-25015	.PIN, cotter	1	
20	90387-087K5	.COLLAR	1	
21	1RM-27420-00-93	FRONT FOOTREST ASSY (RIGHT)	1	CHROME PLATED
22	1NH-27413-00	.COVER, footrest	1	
23	90176-06058	.NUT, crown	2	
24	90508-18696	.SPRING, torsion	1	
25	91701-08038	.PIN, clevis	1	
26	91401-25015	.PIN, cotter	1	
27	90387-087K5	.COLLAR	1	
28	4X7-27414-00	DAMPER, footrest	4	

E8

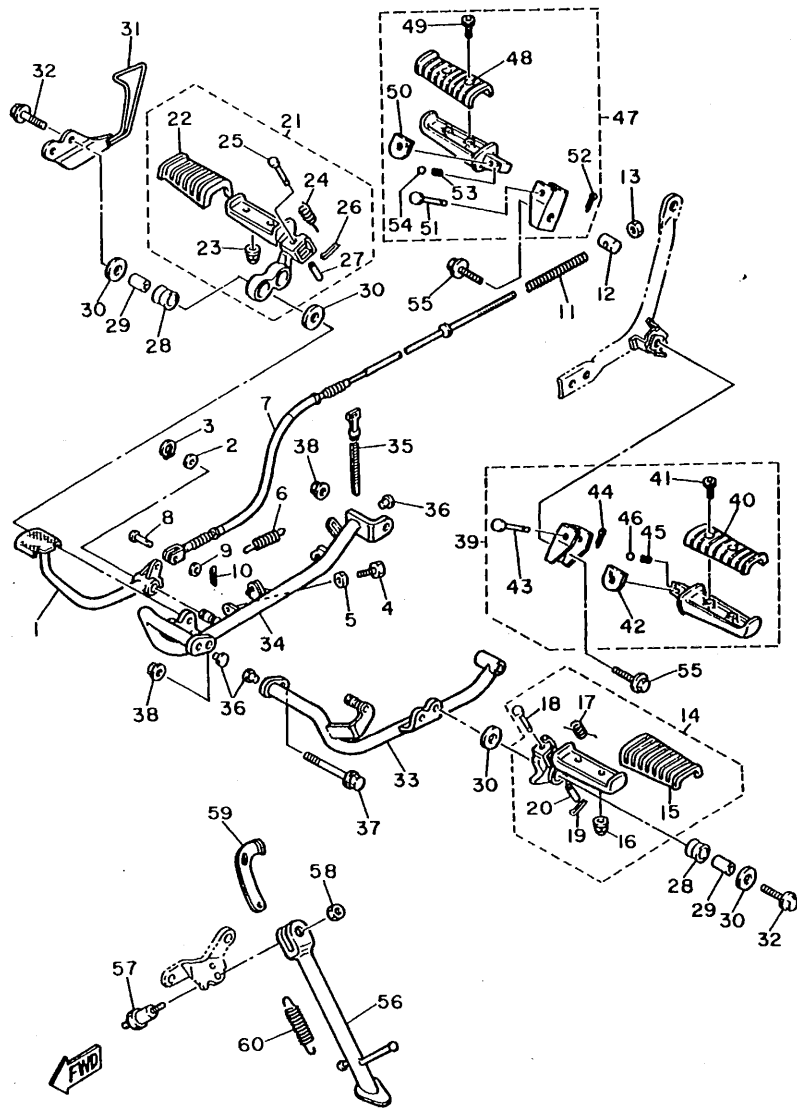

2NT010-7350

FIG. 35 STAND. FOOTREST

REF. NO.	PART NO.	DESCRIPTION	Q'TY	REMARKS
29	90387-107A7	COLLAR	4	
30	90201-100A1	WASHER, plate	6	
31	2GV-27491-00	PROTECTOR	1	
32	90109-100G0	BOLT	4	
33	2GV-27471-00	BAR, footrest 1	1	
34	2GV-27472-00	BAR, footrest 2	1	
35	90465-13169	CLAMP	1	
36	90338-09161	PLUG	3	
37	90105-10312	BOLT, washer based	1	
38	95701-10500	NUT, flange	2	
39	2NT-27430-01	REAR FOOTREST ASSY 1	1	
40	1NH-27433-00	.COVER, rear footrest	1	
41	92016-06012	.BOLT	2	
42	2NT-27437-00	.WASHER, special	1	
43	91701-06032	.PIN, clevis	1	
44	91401-20015	.PIN, cotter	1	
45	90501-12743	.SPRING, compression	1	
46	93501-04011	.BALL	1	
47	2NT-27440-01	REAR FOOTREST ASSY 2	1	
48	1NH-27433-00	.COVER, rear footrest	1	
49	92016-06012	.BOLT	2	
50	2NT-27437-00	.WASHER, special	1	
51	91701-06032	.PIN, clevis	1	
52	91401-20015	.PIN, cotter	1	
53	90501-12743	.SPRING, compression	1	
54	93501-04011	.BALL	1	
55	95811-10016	BOLT, flange	2	
56	2GV-27311-00-R4	STAND, side	1	BLACK

E9

FIG. 35 STAND, FOOTREST

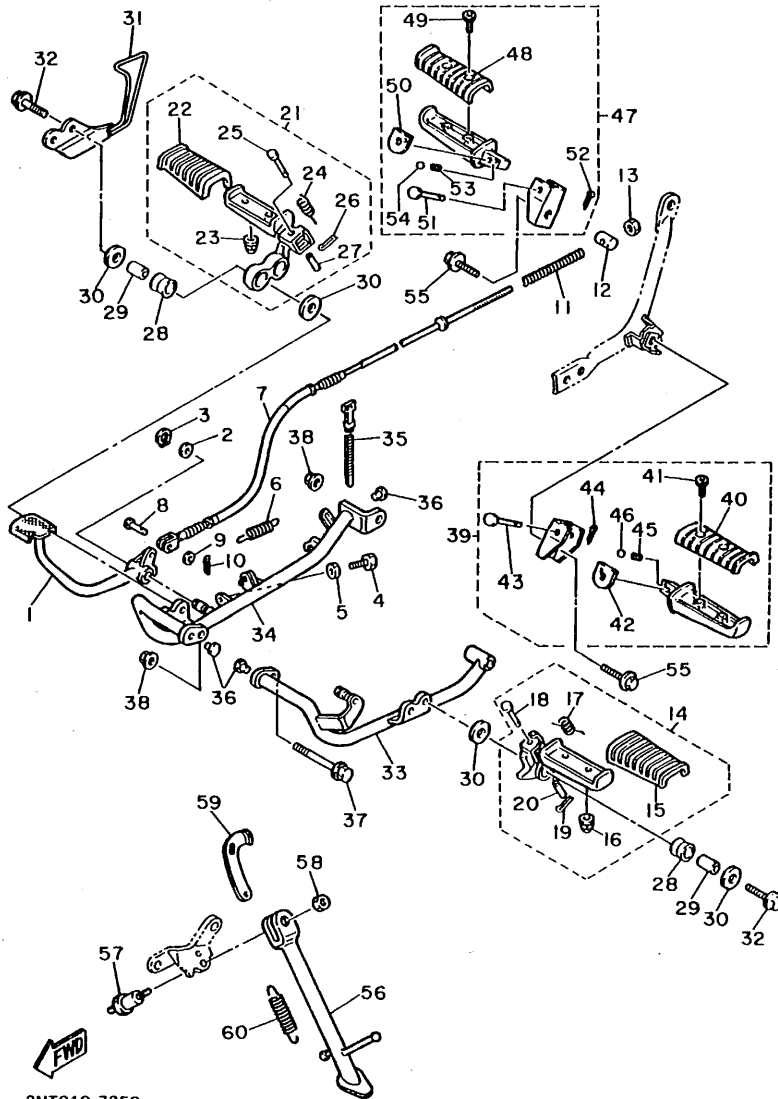

2NT010-7350

REF. NO.	PART NO.	DESCRIPTION	Q'TY	REMARKS
57	90109-10474	BOLT	1	
58	90185-10037	NUT, self-locking	1	
59	5H0-27315-00	LINK, side stand	1	
60	90506-29266	SPRING, tension	1	

FIG. 36 GENERATOR

REF. NO.	PART NO.	DESCRIPTION	Q'TY	REMARKS
1	3BT-81450-00	ROTOR ASSY	1	
2	2GV-81410-20	STATOR ASSY	1	
3	98501-06025	SCREW, pan head	3	
4	92990-06100	WASHER, spring	3	
5	90201-107K6	WASHER, plate	1	
6	90105-10152	BOLT, washer based	1	
7	3BT-81670-00	PICK-UP ASSY	1	
8	98501-06020	SCREW, pan head	3	
9	92990-06100	WASHER, spring	3	

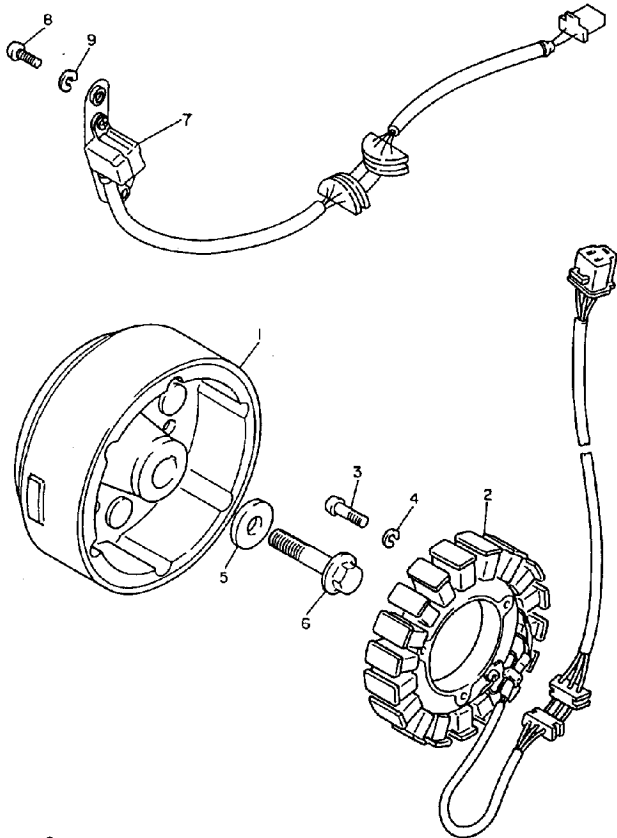

3JC6100-5350

FIG. 37 STARTING MOTOR

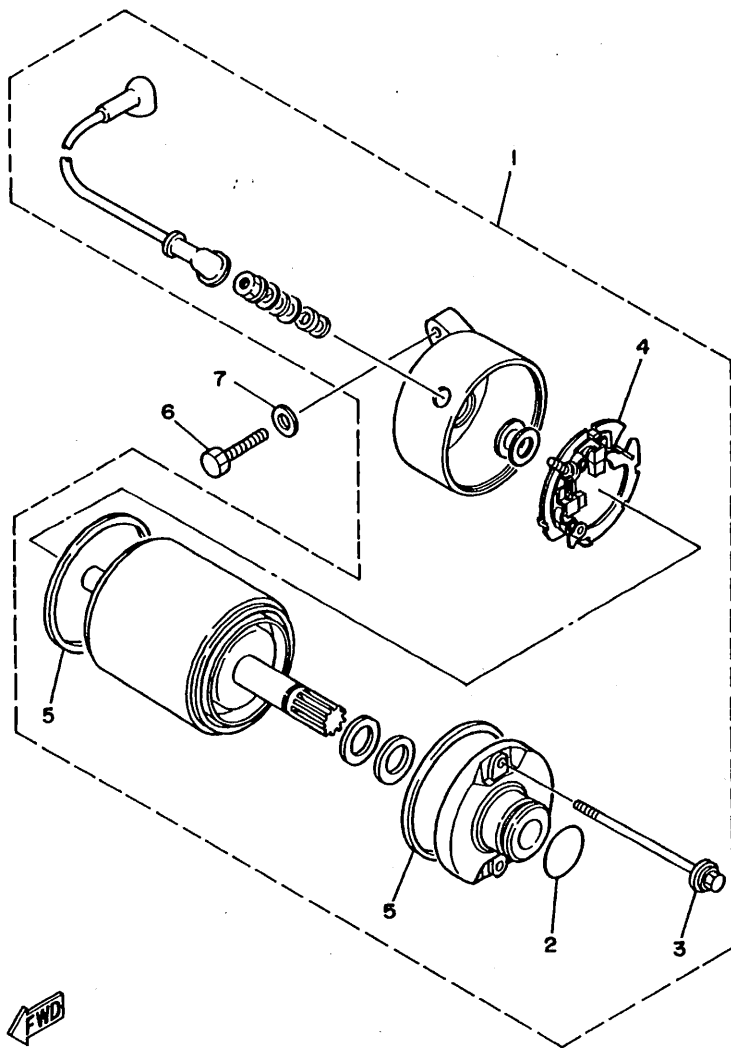

REF. NO.	PART NO.	DESCRIPTION	Q'TY	REMARKS
1	3JB-81800-00	STARTING MOTOR ASSY	1	
2	26H-81847-00	.O-RING	1	
3	3HE-81826-00	.BOLT	2	
4	3KS-81840-00	.BRUSH HOLDER ASSY	1	
5	11H-81844-00	.GASKET	2	
6	97021-06025	BOLT	2	
7	92901-06600	WASHER, plate	2	



3JB1010-9370

E12

FIG. 38 FLASHER LIGHT

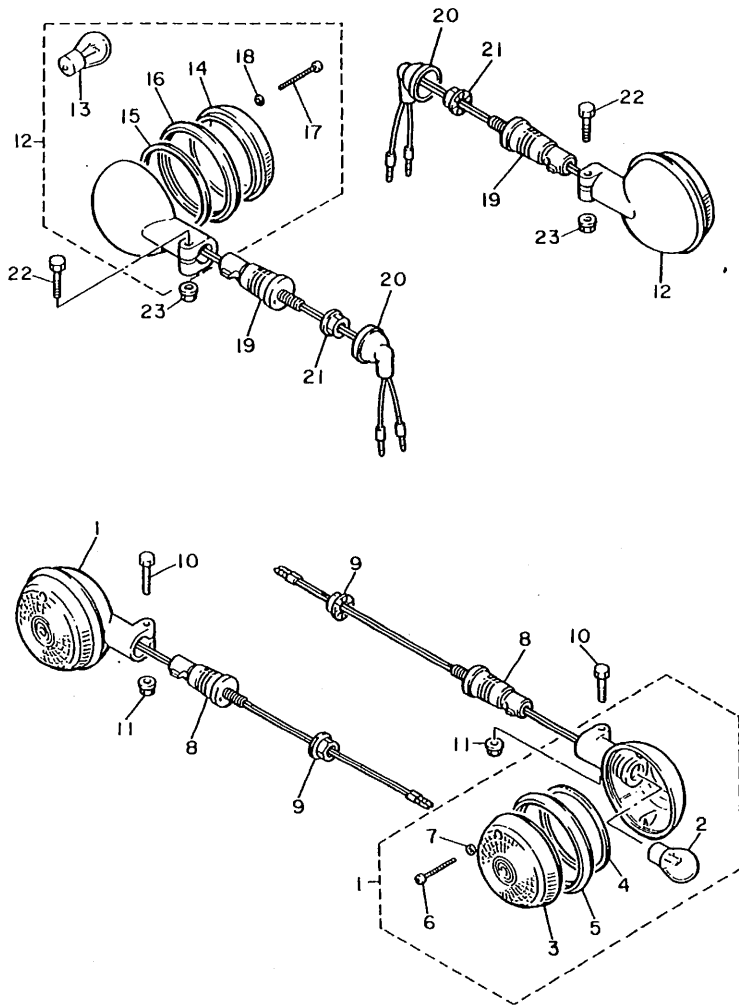

REF. NO.	PART NO.	DESCRIPTION	Q'TY	REMARKS
1	3LS-83310-00	FRONT FLASHER LIGHT ASSY 1	2	
2	1KT-83311-00	.BULB (12V 21W)	1	
3	42X-83312-00	.LENS, flasher	1	
4	42X-83313-00	.GASKET, flasher lens	1	
5	42X-83363-00	.LENS, rim	1	
6	341-83333-70	.SCREW, lens fitting	2	
7	42X-83359-00	.WASHER, special	2	
8	1AA-83318-00	STAY, flasher l	2	
9	95303-12600	NUT	2	
10	90101-06760	BOLT	2	
11	95701-06500	NUT, flange	2	
12	2EN-83330-00	REAR FLASHER LIGHT ASSY 1	2	
13	1KT-83311-00	.BULB (12V 21W)	1	
14	2AE-83312-00	.LENS, flasher	1	
15	42X-83313-00	.GASKET, flasher lens	1	
16	42X-83363-00	.LENS, rim	1	
17	341-83333-70	.SCREW, lens fitting	2	
18	42X-83359-00	.WASHER, special	2	
19	1AA-83318-00	STAY, flasher l	2	
20	18G-83365-00	CAP	2	
21	95302-12600	NUT	2	
22	90101-06760	BOLT	2	
23	95701-06500	NUT, flange	2	



2NT010-7380

E13

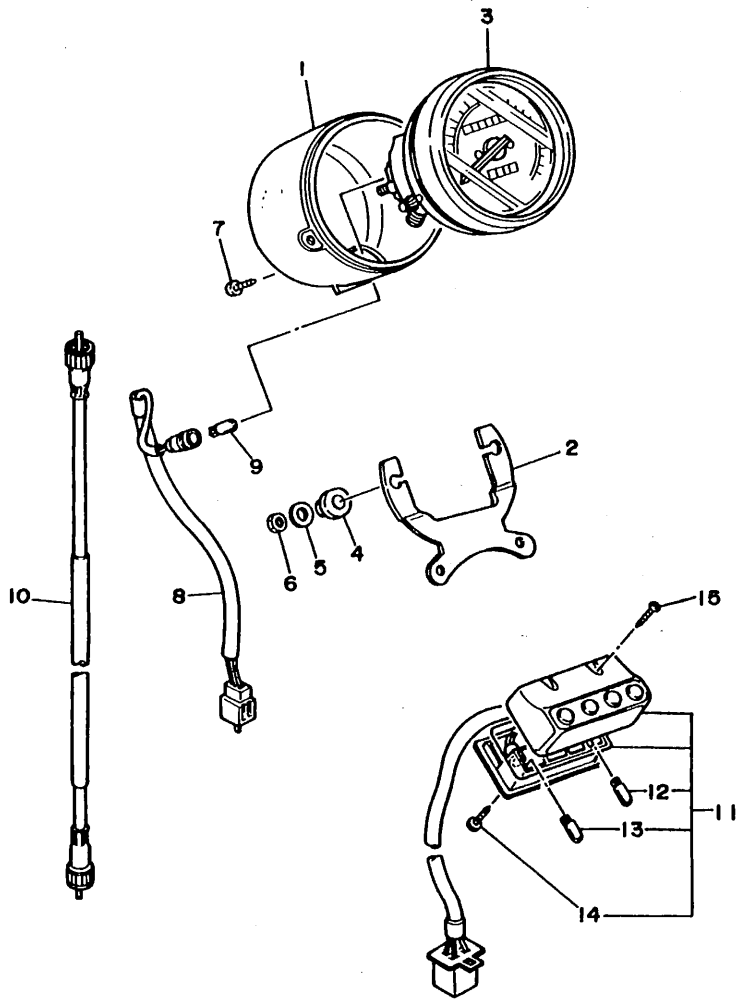

FIG. 39 METER

REF. NO.	PART NO.	DESCRIPTION	Q'TY	REMARKS
1	1FK-83507-00	COVER, speedometer	1	
2	2GV-83519-00	BRACKET, meter	1	
3	3BT-8351A-00	METER ASSY (mph)	1	
4	12R-83513-00	DAMPER	2	
5	90201-05031	WASHER, plate	2	
6	95303-05600	NUT	2	
7	90164-04009	SCREW, tapping	1	
8	2GV-83509-00	SOCKET CORD ASSY	1	
9	42X-83517-00	BULB (12V-3W)	1	
10	34L-83550-01	SPEEDOMETER CABLE ASSY	1	
11	3BT-83530-10	PILOT LIGHT ASSY	1	
12	42X-83517-00	.BULB (12V-3W)	2	
13	2GV-83517-00	.BULB (12V-1.7W)	1	
14	90164-03010	.SCREW, tapping	1	
15	98511-04025	SCREW, pan head	2	

3BM436I-0370

E14

FIG. 40 HEADLIGHT

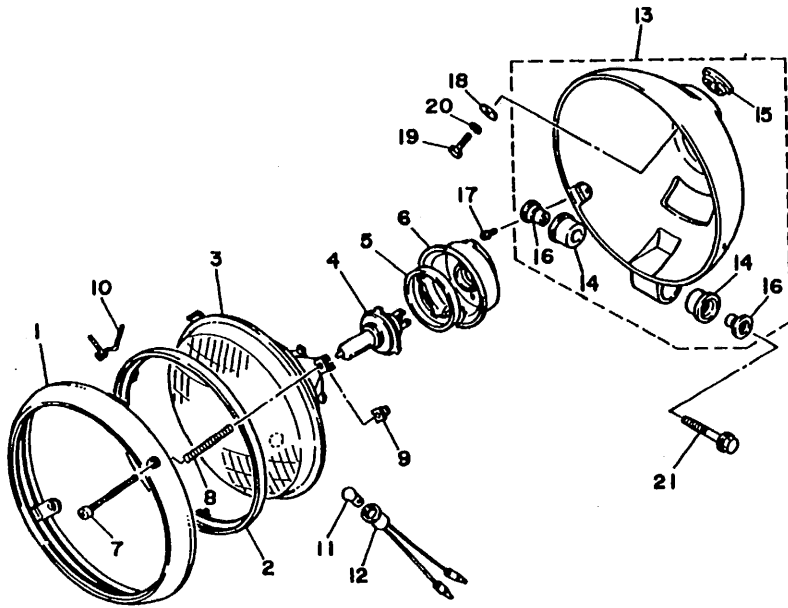

REF. NO.	PART NO.	DESCRIPTION	Q'TY	REMARKS
1	42X-84315-01	RIM, headlight	1	
2	5Y3-84395-00	RING, retaining	1	
3	55R-84321-H0	LENS ASSY	1	
4	2F9-84314-00	BULB (12V-60/55W)	1	HALOGEN
5	2F9-84375-00	FITTING PLATE, bulb	1	
6	2F9-84397-01	COVER, socket	1	
7	20X-84331-00	SCREW, rim adjusting	2	
8	1A0-84332-60	SPRING, screw	2	
9	198-84334-60	NUT, adjusting	2	
10	42X-84124-60	SPRING, set	1	
11	123-83516-21	BULB (12V-3.4W)	1	
12	34L-84346-00	SOCKET, pilot light	1	
13	42X-84330-01	BODY ASSY	1	EMPRESS MAROON
14	42X-84345-00	.DAMPER, headlight	2	
15	42X-84366-00	.DAMPER, headlight 1	1	
16	42X-84338-00	.COLLAR, body fitting	2	
17	90157-05084	SCREW, pan head	2	
18	90201-061H3	WASHER, plate	1	
19	97313-06016	BOLT	1	
20	92990-06100	WASHER, spring	1	
21	95021-08040	BOLT, flange	1	



38T3300-9520

E15

FIG. 41 TAILLIGHT

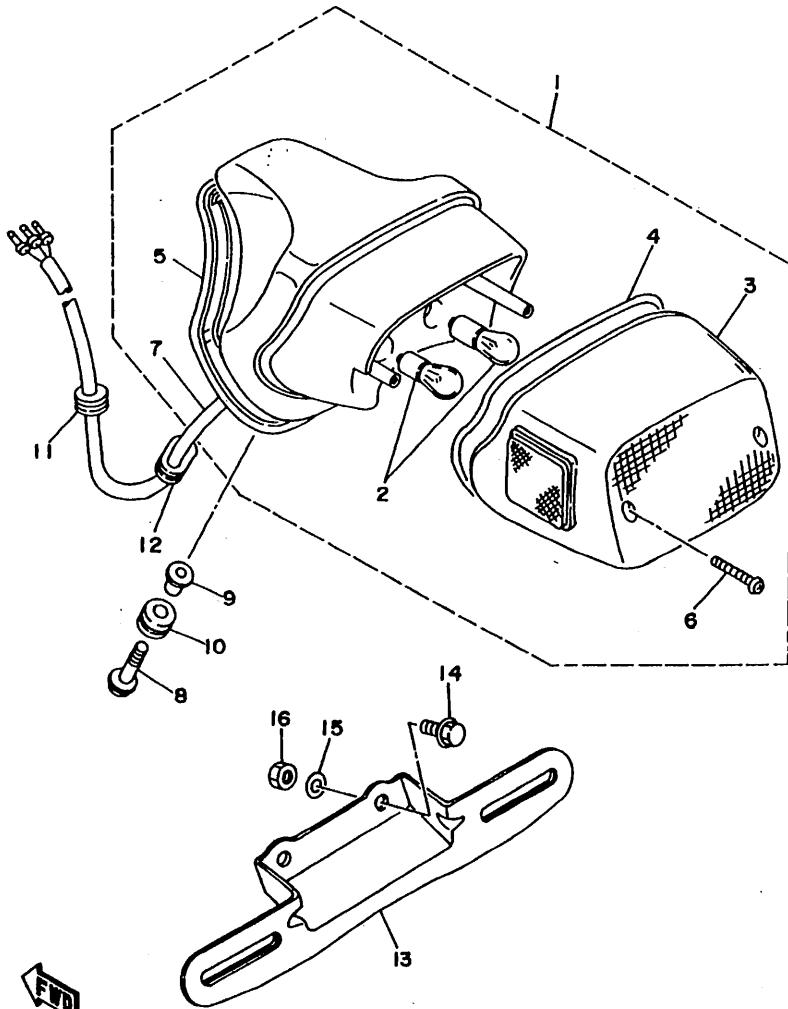

REF. NO.	PART NO.	DESCRIPTION	Q'TY	REMARKS
1	2YL-84700-E0	TAILLIGHT ASSY	1	
2	31L-84714-00	.BULB, taillight (12V-21/5W)	2	
3	2AE-84721-00	.LENS, taillight	1	
4	42X-84723-01	.GASKET, tail lens	1	
5	1RM-84704-00	.GASKET, taillight	1	
6	97701-40525	.SCREW, tapping	2	
7	2GV-84717-00	.CORD, taillight	1	
8	90119-06097	BOLT, with washer	3	
9	90387-06026	COLLAR	3	
10	90480-14229	GROMMET	3	
11	90480-16112	GROMMET	1	
12	90480-15061	GROMMET	2	
13	2YL-84751-00	BRACKET, license	1	
14	95811-06016	BOLT, flange	2	
15	92990-06200	WASHER, plain	2	
16	95303-06600	NUT	2	



38TP332-3390

F2

FIG. 42 HANDLE SWITCH. LEVER (FLAT HANDLE)

REF. NO.	PART NO.	DESCRIPTION	Q'TY	REMARKS
1	11U-82911-00	HOLDER, lever 1	1	
2	1AA-83912-00	LEVER 1	1	
3	2NT-82917-00	SWITCH	1	
4	90109-06799	BOLT	1	
5	95616-06100	NUT, u	1	
6	93210-11368	O-RING	1	
7	97011-06025	BOLT	1	
8	92906-06100	WASHER, spring	1	
9	2W1-83922-00	LEVER 2	1	
10	90149-06153	SCREW	1	
11	90170-06010	NUT	1	
12	90501-10312	SPRING, compression	1	
13	90109-06577	BOLT	1	
14	95601-06100	NUT, u	1	
15	3BT-83972-00	SWITCH, handle 4	1	
16	98506-05035	.SCREW, pan head	2	
17	55R-83963-01	SWITCH, handle 3 (RIGHT)	1	
18	98506-05040	.SCREW, pan head	1	
19	98506-05045	.SCREW, pan head	1	
20	437-83936-01	BAND, switch cord	2	
21	3JB-83964-00	SWITCH	1	
22	98511-04012	.SCREW, pan head	2	
23	437-83936-11	BAND, switch cord	2	

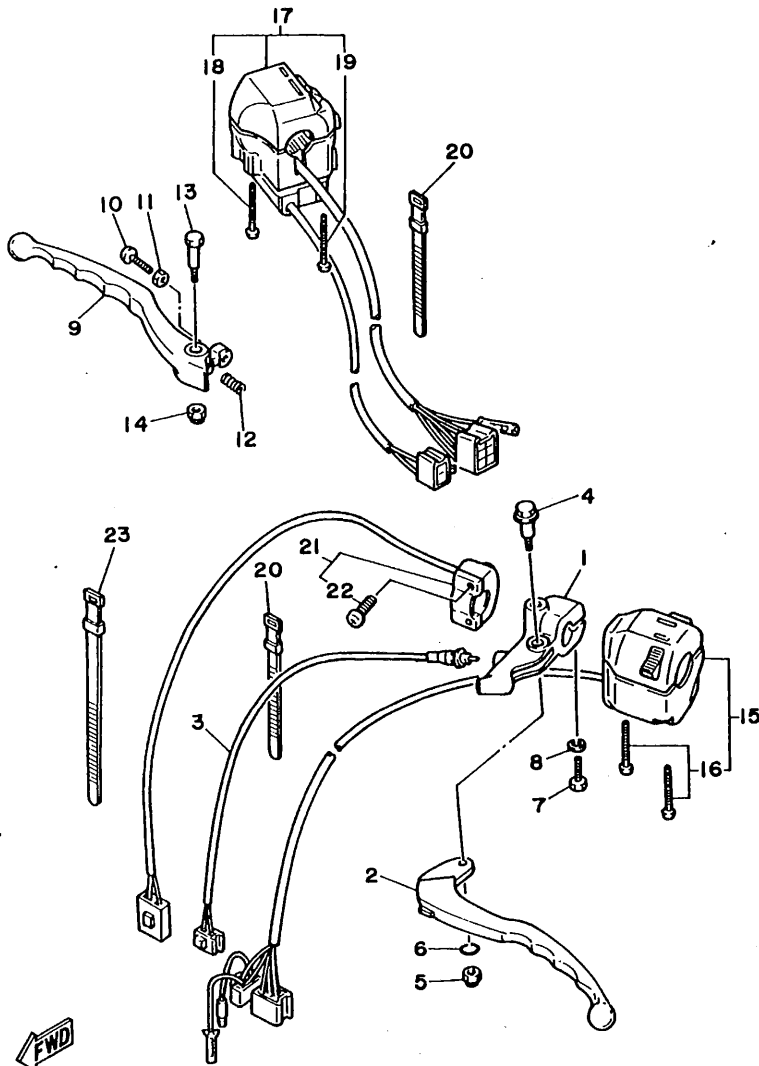

3BT3351-9420

F3

FIG. 43 HANDLE SWITCH. LEVER (UP HANDLE)

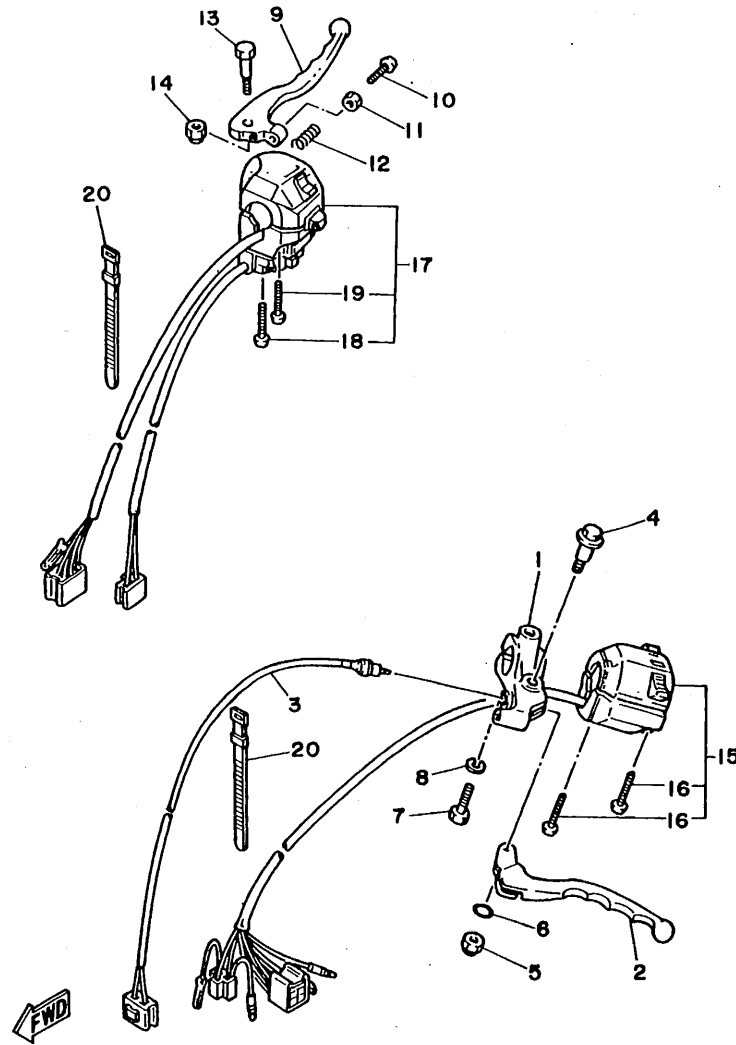

3BT3351-9430

REF. NO.	PART NO.	DESCRIPTION	Q'TY	REMARKS
1	10M-82911-00	HOLDER, lever 1	1	
2	26V-83912-00	LEVER 1	1	
3	26V-82917-00	SWITCH	1	
4	90109-06799	BOLT	1	
5	95616-06100	NUT, u	1	
6	93210-11368	O-RING	1	
7	97011-06025	BOLT	1	
8	92906-06100	WASHER, spring	1	
9	2W1-83922-00	LEVER 2	1	
10	90149-06153	SCREW	1	
11	90170-06010	NUT	1	
12	90501-10312	SPRING, compression	1	
13	90109-06577	BOLT	1	
14	95601-06100	NUT, u	1	
15	2YL-83972-00	SWITCH, handle 4	1	
16	98501-05035	.SCREW, pan head	2	
17	2NU-83972-10	SWITCH, handle 4	1	
18	98506-05040	.SCREW, pan head	1	
19	98506-05045	.SCREW, pan head	1	
20	437-83936-01	BAND, switch cord	4	

F4

FIG. 44 ELECTRICAL 1

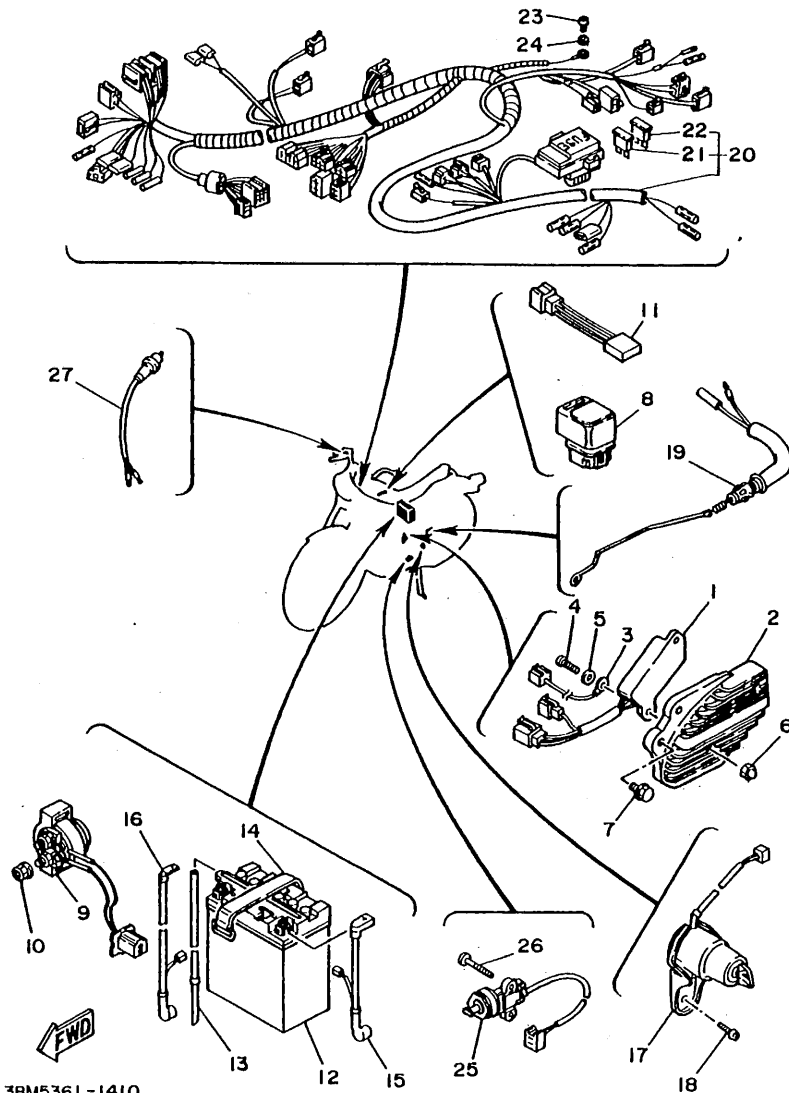

REF. NO.	PART NO.	DESCRIPTION	Q'TY	REMARKS
1	42X-81960-A1	RECTIFIER & REGULATOR ASSY	1	
2	3JB-81975-00	PLATE, rectifier fitting	1	
3	3LR-83364-00	WIRE, earth lead 2	1	
4	98502-06016	SCREW, pan head	2	
5	92990-06600	WASHER, plate	2	
6	90176-06072	NUT, crown	2	
7	95801-06012	BOLT, flange	2	
8	25G-81950-01	RELAY ASSY	1	
9	3AY-81940-00	STARTER RELAY ASSY	1	
10	95701-06500	NUT, flange	2	
11	4H7-81980-M0	RECTIFIER 2	1	
12	1VJ-82110-60	BATTERY ASSY (GM12AZ-3A-2)	1	
13	90445-08248	HOSE	1	
14	120-82131-00	BAND, battery	1	
15	2GV-82115-00	WIRE, plus lead	1	
16	2GV-82116-00	WIRE, minus lead	1	
17	2NT-82510-01	MAIN SWITCH ASSY	1	
18	92016-08016	SCREW	1	
19	2GV-82530-03	STOP SWITCH ASSY	1	
20	3BT-82590-10	WIRE HARNESS ASSY	1	
21	36Y-82151-00	.FUSE (15A)	4	
22	1AE-82151-00	.FUSE (30A)	2	
23	98501-06010	SCREW, pan head	1	
24	92990-06600	WASHER, plate	1	
25	3LD-82566-70	SWITCH, side stand	1	
26	90157-05079	SCREW, pan head	2	
27	2NT-83980-00	FRONT STOP SWITCH ASSY	1	

FIG. 45 ELECTRICAL 2

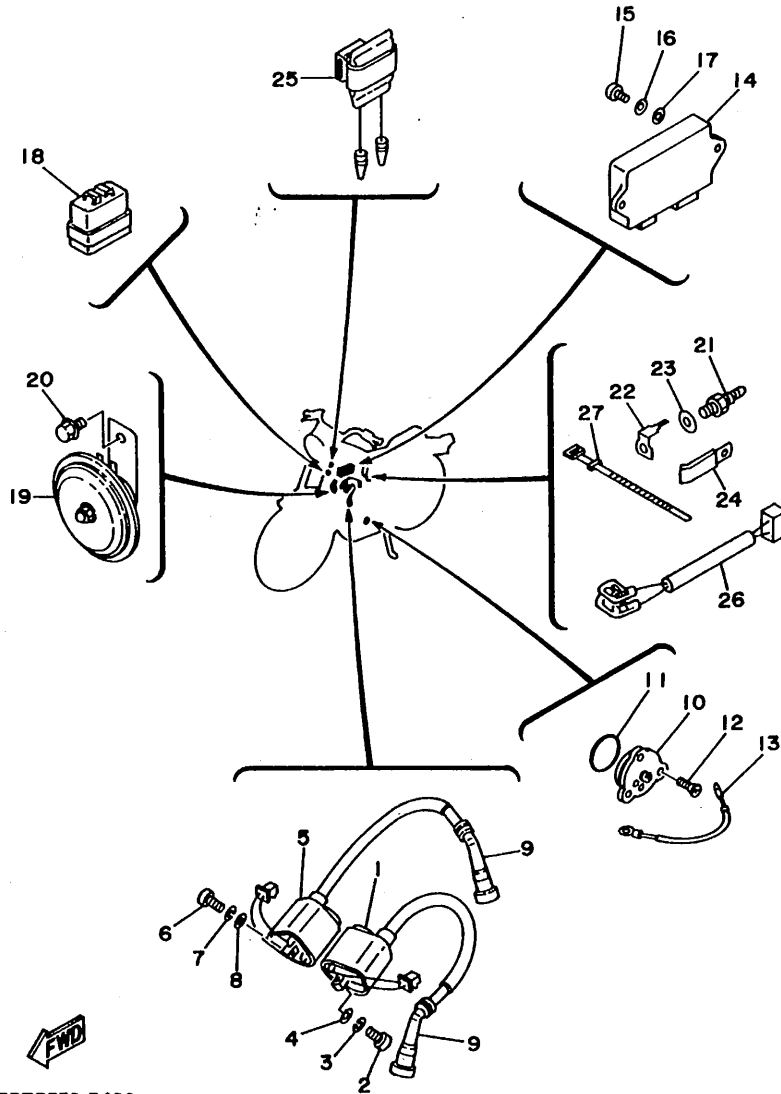

3BTP332-3420

REF. NO.	PART NO.	DESCRIPTION	Q'TY	REMARKS
1	2GV-82310-21	IGNITION COIL ASSY	1	
2	98506-05016	SCREW, pan head	2	
3	92906-05100	WASHER, spring	2	
4	92906-05600	WASHER, plate	2	
5	2GV-82320-20	IGNITION COIL ASSY	1	
6	98506-05016	SCREW, pan head	2	
7	92906-05100	WASHER, spring	2	
8	92906-05600	WASHER, plate	2	
9	2GV-82370-00	PLUG CAP ASSY	2	
10	1L9-82540-00	NEUTRAL SWITCH ASSY	1	
11	93210-29196	O-RING	1	
12	98701-05012	SCREW, flat head	3	
13	1FK-82541-00	WIRE, lead	1	
14	3BT-82305-00	IGNITOR UNIT ASSY	1	
15	98501-06020	SCREW, pan head	2	
16	92990-06100	WASHER, spring	2	
17	92990-06600	WASHER, plate	2	
18	4TR-83350-71	FLASHER RELAY ASSY	1	
19	35J-83371-30	HORN	1	
20	95826-06010	BOLT, flange	1	
21	3LS-82790-00	CARB. HEATER ASSY	2	FOR ENGLAND, HOLLAND
22	1AJ-82103-00	TERMINAL	2	FOR ENGLAND, HOLLAND
23	90201-081K4	WASHER, plain	2	FOR ENGLAND, HOLLAND
24	3UH-14146-00	PLATE	1	FOR ENGLAND, HOLLAND
25	4FY-82560-00	THERM. SWITCH	1	FOR ENGLAND, HOLLAND
26	3BT-82509-00	WIRE, sub-lead	2	FOR ENGLAND, HOLLAND
27	437-83936-01	BAND, switch cord	2	FOR ENGLAND, HOLLAND

F6



INDIVIDUAL SPEC.

FOR ITALY

FOR HOLLAND

FOR GREECE

The following pages provides a listing of only the parts that meet the specifications peculiar to your market. For those parts not appearing in these pages, refer to the "GENERAL SPEC" section.

FIG. 46 ALTERNATE (CHASSIS)

REF. NO.	PART NO.	DESCRIPTION	Q'TY	REMARKS
1	3BR-21610-00-P0	REAR FENDER COMP.	*	UR LIGHT GRAYISH BLUE METALLIC 1
	3BR-21610-00-R0	REAR FENDER COMP.	*	UR GRACEFUL MAROON
	3BR-21610-00-4B	REAR FENDER COMP.	*	UR BLACK 2
2	3JB-21641-00	BRACKET, reflector	1	
3	90267-48104	RIVET, blind	2	
4	3Y6-85130-02	REAR REFLECTOR ASSY	1	
5	95306-05800	NUT, cap	1	
6	3JB-21610-00-P0	REAR FENDER COMP.	1	UR LIGHT GRAYISH BLUE METALLIC 1
	3JB-21610-00-R0	REAR FENDER COMP.	1	UR GRACEFUL MAROON
	3JB-21610-00-4B	REAR FENDER COMP.	1	UR BLACK 2
7	3BR-21621-00	FLAP	*	
8	4G0-21639-00	DAMPER 2	*	
9	92506-06012	SCREW, pan head	*	
10	92906-06600	WASHER, plate	*	
11	90430-06139	GASKET	*	
12	92990-06200	WASHER, plain	*	
13	95303-06600	NUT	*	
14	2AE-21641-00	BRACKET, reflector	*	
15	90267-40076	RIVET, blind	*	
16	90201-044A2	WASHER, plate	*	
17	449-85131-02	REFLECTOR, rear 1	*	

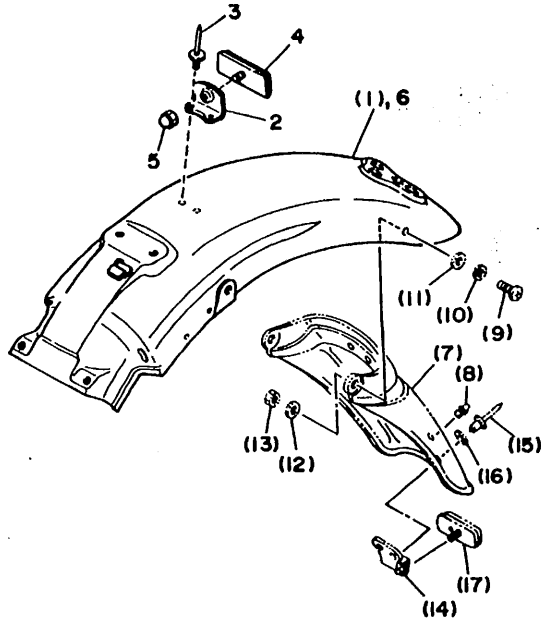

* For convenience of reference:

Disregard the items asterisked (*) in the "QTY" column. These are intended for GENERAL SPEC, and NOT for INDIVIDUAL SPEC.



3BTR300-3460

F8

FIG. 47 ALTERNATE (HEADLIGHT)

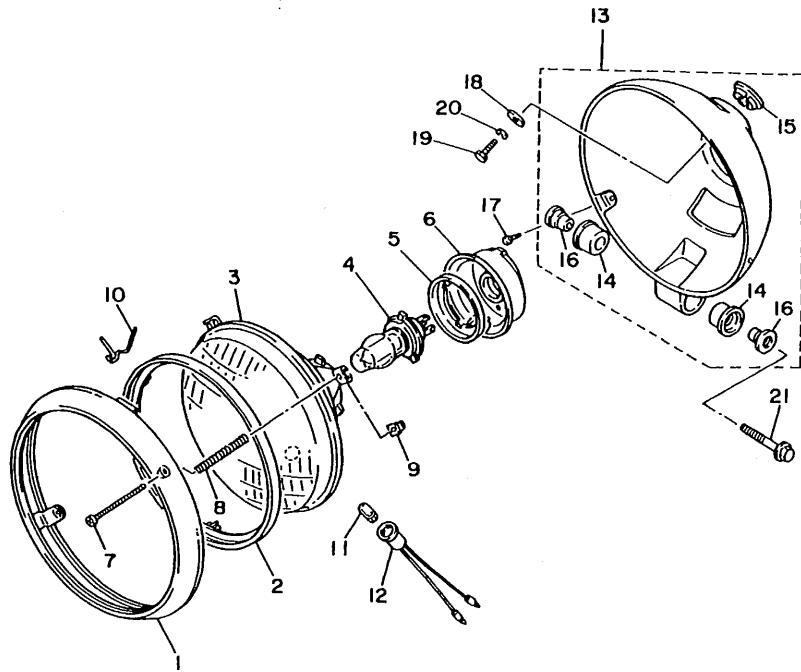

REF. NO.	PART NO.	DESCRIPTION	Q'TY	REMARKS
1	42X-84315-01	RIM, headlight	1	
2	5Y3-84395-00	RING, retaining	1	
3	2AE-84320-60	LENS ASSY	1	
4	2F9-84314-00	BULB (12V-60/55W)	1	LM
5	2F9-84375-00	FITTING PLATE, bulb	1	
6	2F9-84397-01	COVER, socket	1	
7	20X-84331-00	SCREW, rim adjusting	2	
8	1A0-84332-60	SPRING, screw	2	
9	198-84334-60	NUT, adjusting	2	
10	42X-84124-60	SPRING, set	1	
11	4E2-84347-00	BULB (12V-4W)	1	
12	34L-84346-00	SOCKET, pilot light	1	
13	42X-84330-01	BODY ASSY	1	
14	42X-84345-00	.DAMPER, headlight	2	
15	42X-84366-00	.DAMPER, headlight 1	1	
16	42X-84338-00	.COLLAR, body fitting	2	
17	90157-05084	SCREW, pan head	2	
18	90201-061H3	WASHER, plate	1	
19	97313-06016	BOLT	1	
20	92990-06100	WASHER, spring	1	
21	95021-08040	BOLT	1	



38T3300-9400

F9

FIG. 48 ALTERNATE (TAILLIGHT)

REF. NO.	PART NO.	DESCRIPTION	Q'TY	REMARKS
1	90480-16112	GROMMET	*	
2	90480-16501	GROMMET	1	
3	90480-15061	GROMMET	*	
4	90480-01502	GROMMET	2	
5	92990-06200	WASHER, plain	*	
6	95303-06600	NUT	*	
7	3BT-8351A-00	METER ASSY	*	
8	2JV-8351A-F0	METER ASSY	1	

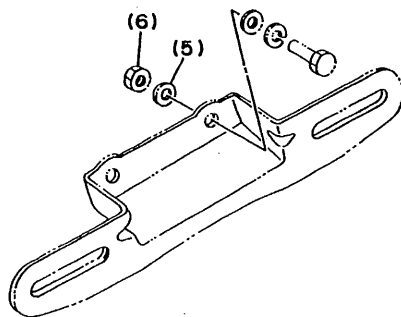
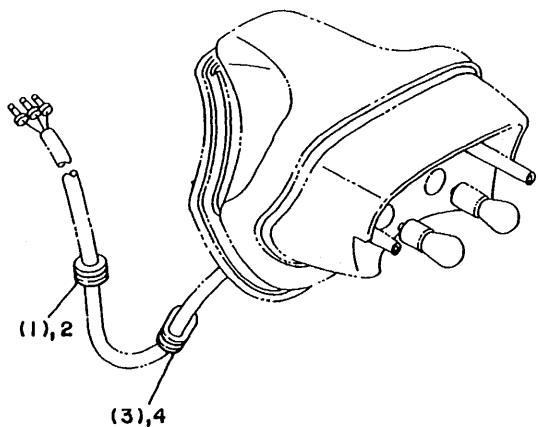
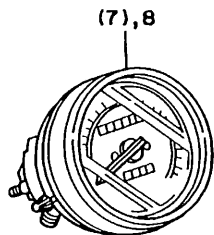

3BTE300-1480

* For convenience of reference:

Disregard the items asterisked (*) in the "QTY" column. These are intended for GENERAL SPEC, and NOT for INDIVIDUAL SPEC.

F10

FOR SWEDEN

FOR FINLAND

FOR NORWAY

The following pages provides a listing of only the parts that meet the specifications peculiar to your market. For those parts not appearing in these pages, refer to the "GENERAL SPEC" section.

FIG. 49 ALTERNATE (CHASSIS)

REF. NO.	PART NO.	DESCRIPTION	Q'TY	REMARKS
1	3BT-21110-10-33	FRAME COMP.	*	YAMAHA BLACK
2	3BT-21110-00-33	FRAME COMP.	1	YAMAHA BLACK
3	2A6-23408-00	STEERING LOCK ASSY	*	
4	*	STEERING LOCK ASSY	1	LM
5	90502-09024	SPRING, conical	*	
6	3DM-23484-00	CAP, handle lock	*	
7	134-23484-10	CAP, handle lock	1	

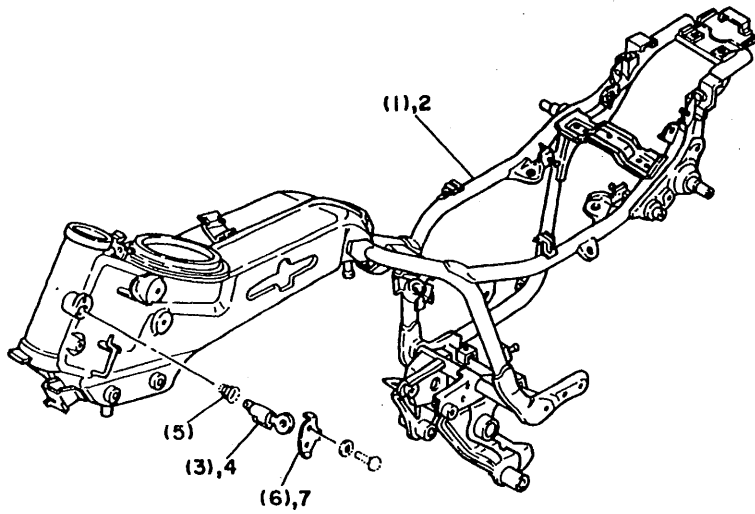

3BTR300-3490

F12

* For convenience of reference:

Disregard the items asterisked (*) in the "QTY" column. These are intended for GENERAL SPEC, and NOT for INDIVIDUAL SPEC.

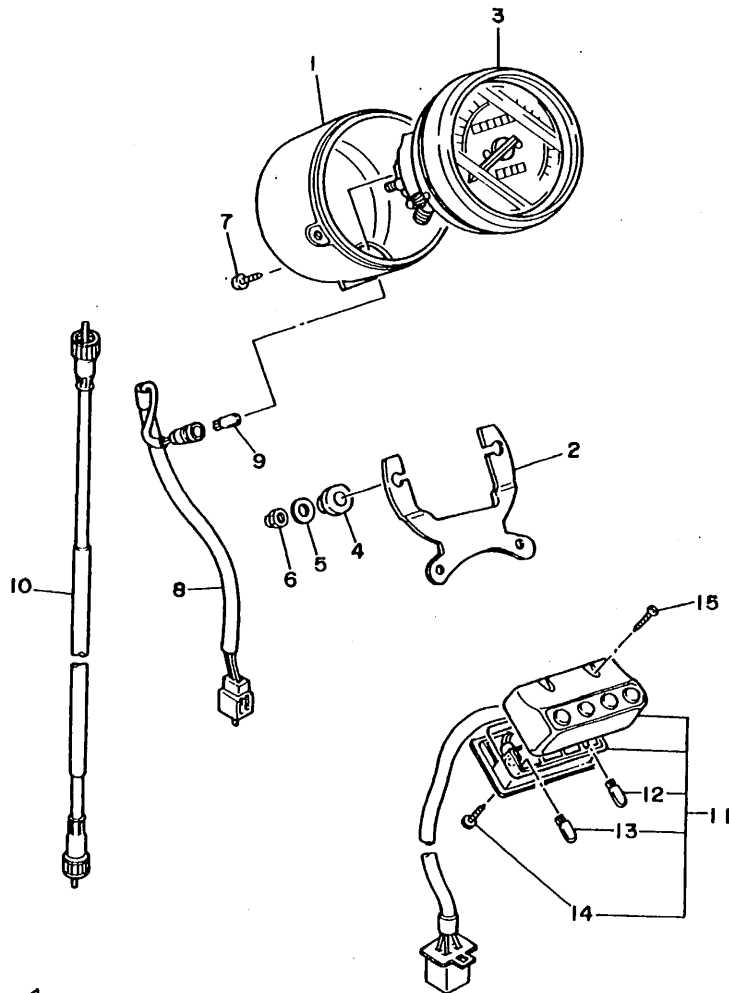

FIG. 50 ALTERNATE (METER)

REF. NO.	PART NO.	DESCRIPTION	Q'TY	REMARKS
1	1FK-83507-00	COVER, speedometer	1	
2	2GV-83519-00	BRACKET, meter	1	
3	2JV-8351A-F0	METER ASSY	1	
4	12R-83513-00	DAMPER	2	
5	90201-05031	WASHER, plate	2	
6	95303-05600	NUT	2	
7	90164-04009	SCREW, tapping	1	
8	2GV-83509-00	SOCKET CORD ASSY	1	
9	42X-83517-00	BULB (12V-3W)	1	
10	34L-83550-01	SPEEDOMETER CABLE ASSY	1	
11	3BT-83530-10	PILOT LIGHT ASSY	1	
12	42X-83517-00	.BULB (12V-3W)	2	
13	2GV-83517-00	.BULB (12V-1.7W)	1	
14	90164-03010	.SCREW, tapping	1	
15	98511-04025	SCREW, pan head	2	



3BM436I-0370

F13

FIG. 51 ALTERNATE (HEADLIGHT)

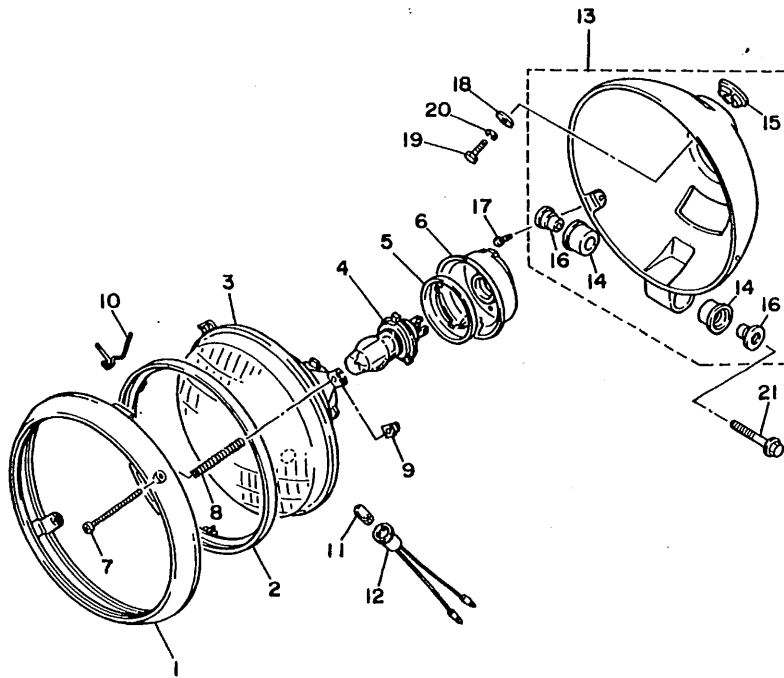

REF. NO.	PART NO.	DESCRIPTION	Q'TY	REMARKS
1	42X-84315-01	RIM, headlight	1	
2	5Y3-84395-00	RING, retaining	1	
3	2AE-84320-60	LENS ASSY	1	
4	2F9-84314-00	BULB (12V-60/55W)	1	HALOGEN
5	2F9-84375-00	FITTING PLATE, bulb	1	
6	2F9-84397-01	COVER, socket	1	
7	20X-84331-00	SCREW, rim adjusting	2	
8	1A0-84332-60	SPRING, screw	2	
9	198-84334-60	NUT, adjusting	2	
10	42X-84124-60	SPRING, set	1	
11	4E2-84347-00	BULB (12V-4W)	1	
12	34L-84346-00	SOCKET, pilot light	1	
13	42X-84330-01	BODY ASSY	1	EMPRESS MAROON
14	42X-84345-00	.DAMPER, headlight	2	
15	42X-84366-00	.DAMPER, headlight 1	1	
16	42X-84338-00	.COLLAR, body fitting	2	
17	90157-05084	SCREW, pan head	2	
18	90201-061H3	WASHER, plate	1	
19	97313-06016	BOLT	1	
20	92990-06100	WASHER, spring	1	
21	95021-08040	BOLT	1	



3BT3300-9400

F14

INDEX

(GENERAL SPEC.)

NUMERICAL INDEX

PART NO.	GRID NO.	PART NO.	GRID NO.	PART NO.	GRID NO.	PART NO.	GRID NO.	PART NO.	GRID NO.	PART NO.	GRID NO.
4H7-W0041-00	E- 6	2GV-11638-00	B- 5	22V-14147-00	B-12	2NT-15415-00	C- 2	1J7-17537-Y0-40	D- 4	3BR-21610-00-RO	C-13
	E- 7	22U-11650-00	B- 5	137-14153-00	B-11	2NT-15421-00	C- 2	1J7-17537-Y0-50	D- 4	3BR-21610-00-4B	C-13
3JB-W0045-00	D-15	22U-11654-00	B- 5	1FK-14190-15	B-11	22U-15441-01	B-15	1J7-17537-Y0-60	D- 4	3BR-21621-00	C-14
2GV-W0047-00	D-15	22U-11656-00	B- 5	2L1-14191-00	B-12	3BT-15451-00	C- 2	4H7-17537-00-20	C- 8	2GV-21629-00-PO	C-13
51L-W0048-00	D-15	22U-11656-10	B- 5	2GV-14197-00	B-10	3BT-15461-00	C- 2	4H7-17537-00-30	C- 8	2GV-21629-00-RO	C-13
2GV-W0057-00	D-15	22U-11656-20	B- 5	3G2-14231-14	B-11	3BT-15484-00	C- 2	4H7-17537-00-40	C- 8	2GV-21629-00-4B	C-13
4H7-W1752-10	C- 8	22U-11656-30	B- 5	3G2-14231-27	B-12	22U-15512-00	C- 4	22U-17553-00	C- 8	2GV-2163A-00	C-13
2GV-W2341-00-38	D- 6	22U-12111-00	B- 6	3G2-14231-34	B-11	22U-15517-00	C- 4	22U-17556-00	C- 8	2GV-2163E-00	C-13
3JB-W2341-00-38	D- 6	22U-12113-00	B- 6	2GV-14412-00	B-10	5H0-15521-00	C- 4	2H7-17590-00	D- 5	4G0-21639-00	C-14
3DR-W2536-00	E- 2	22U-12114-00	B- 6	2GV-14451-00	B-10	22U-15580-00	C- 4	2GV-18110-00	C-10	2AE-21641-00	C-14
22U-V1754-00	C- 8	3Y1-12116-00	B- 6	52W-14452-00	B-10	341-15583-05	C- 4	2GV-18112-00	C-10	2GV-2171E-00	C-11
3BR-Y2428-20-PO	D-10	3Y1-12117-01	B- 6	22U-14469-00	B-10	22U-16111-01	C- 5	132-18113-01	C-10	2GV-21711-00-PO	C-15
3BR-Y2428-30-RO	D-10	1J7-12118-00	B- 6	1J7-14277-00	C-15	22U-16150-01	C- 5	2GV-18115-00	C-10	2GV-21711-00-RO	C-15
3BR-Y2428-30-4B	D-10	1J7-12119-01	B- 6	2GV-14484-00	B-13	22U-16154-00	C- 5	22U-18120-00	C-10	2GV-21711-00-4B	C-15
2NT-1110M-00	B- 3	22U-12121-01	B- 6	22U-14536-00	B-11	22U-16321-00	C- 5	4G0-18127-00	C-10	2GV-2172A-00	C-15
2GV-11102-00	B- 2	22U-12151-00	B- 6	22U-14565-00	B-11	4X7-16324-00	C- 5	11H-18140-00	C-10	2GV-2172F-00	C-15
22U-1111F-01	B- 3	22U-12156-01	B- 6	2GV-14603-00	B-13	4X7-16325-00	C- 5	2H9-18154-00	C-10	2GV-21721-00-PO	C-15
2GV-1111H-00	B- 2	22U-12159-00	B- 6	4BE-14613-00	B-13	22U-16351-00	C- 5	16G-18185-00	C- 9	2GV-21721-00-RO	C-15
2GV-11127-00	B- 2	22U-12171-01	B- 7	4BR-14613-00	B-13	5Y1-16356-00	C- 5	11H-18511-00	C- 9	2GV-21721-00-4B	C-15
4H7-11133-10	B- 2	22U-12176-01	B- 7	2GV-14625-00	B-13	22U-16357-00	C- 6	11H-18512-00	C- 9	2GV-21731-00-93	C-15
2GV-11142-00	B- 2	22U-12181-01	B- 7	2GV-14663-00	B-13	30X-16358-00	C- 5	11H-18513-00	C- 9	2GV-2174E-00	C-15
22U-11145-00	B- 7	11H-12210-01	B- 7	2YL-14703-10	B-13	22U-16371-00	C- 5	11H-18531-00	C- 9	3JB-2176E-00	C-15
2GV-11152-00	B- 2	3BT-12213-00	B- 7	22U-1490H-00	B-11	22U-16380-00	C- 5	22U-18535-00	C- 9	3BT-21781-30	C-15
15A-11162-00	B- 4	22U-12231-00	B- 7	2JV-1490J-00	B-11	4X7-16383-01	C- 5	22U-18540-00	C- 9	3BT-21781-40	C-15
22U-11165-00	B- 2	22U-12241-00	B- 7	2JV-1490J-10	B-11	4X7-16384-00	C- 5	278-18542-00	C- 9	3BT-21781-50	C-15
2GV-11166-00	B- 2	22U-13300-00	B- 8	22U-1490K-00	B-12	4X7-16385-00	C- 5	278-18566-00	C- 9	2GV-22110-00-35	D- 3
2GV-11181-00	B- 2	22U-13324-00	B- 8	2GV-1490L-00	B-12	11H-17121-00	C- 7	3JB-21105-00-33	C-11	4X7-22124-00	D- 3
2GV-11185-00	B- 2	22U-13325-00	B- 8	3BT-14900-01	B-11	22U-17131-00	C- 7	3BT-21110-10-30	C-11	4X7-22129-00	D- 3
2NT-11186-00	B- 3	22U-13410-00	B- 8	3BT-14901-01	B-11	22U-17141-00	C- 7	2GV-21171-00	C-15	4X7-22141-00	D- 3
22U-11186-00	B- 2	22U-13415-00	B- 8	3BT-14902-01	B-11	11H-17151-01	C- 7	26H-21308-00	C-13	22U-22189-00	D- 3
2NT-11187-00	B- 3	2GV-13417-00	B- 8	1FK-14933-00	B-11	22U-17211-00	C- 7	22U-21315-00	C-11	2YL-22210-00	D- 3
22U-11187-00	B- 2	4X7-13440-90	B- 9	41R-14940-00	B-11	4A0-17216-00-10	C- 4	22U-21316-00	C-11	2GV-22216-00	D- 3
3BT-11195-00	B- 3	2NT-13447-00	B- 9	22U-14952-00	B-12	22U-17221-00	C- 7	2GV-21317-00	C-11	2YL-22220-00	D- 3
3BT-11196-00	B- 3	11H-13455-00	B- 8	26H-14952-00	B-12	22U-17231-00	C- 7	2GV-21359-00	C-12	2GV-22226-00	D- 3
214-11198-01	B- 8		D- 5	341-14954-00	B-12	22U-17241-00	C- 7	2GV-2138L-00	B-13		D- 3
	D- 5	16G-13569-00	B-10	22U-14968-00	B-11	11H-17251-00	C- 7	2GV-2139R-00	C-12	2GV-22253-00	D- 3
2GV-11310-00	B- 4	2GV-13586-00	B-10	22U-14968-00	B-11	22U-17402-00	C- 7	3JB-2139R-00	C-12	5M0-22253-00	D- 3
2GV-11320-00	B- 4	2GV-13596-00	B-10	3JB-14985-00	B-11	22U-17411-00	C- 7	1AA-2143A-00	C-12	2NT-23102-01	D- 8
3BT-11351-00	B- 4	1HX-13907-00	D-12	2GV-14987-00	B-10	22U-17524-00	C- 8	2GV-21458-00	C-11	2NT-23103-01	D- 8
22U-11411-00	B- 5	11H-1410A-00	B-11	31H-14987-00	B-12	22U-17527-00	C- 8	4X7-21485-00	C-11	2GV-23110-00-93	D- 8
22U-11416-80	B-14	22U-14103-00	B-12	341-14991-00	B-12	3H5-17529-00	C- 8	2GV-21510-00-PO	C-13		D- 8
22U-11416-90	B-14	12R-14105-00	B-12	2GV-15100-00	B-14	3JB-17531-00	C- 8	2GV-21510-00-RO	C-13	1HX-23111-00	D- 8
2GV-11610-00	B- 5	2JU-1414G-00	B-12	22U-15123-00	B-15	3JB-17531-10	C- 8	2GV-21510-00-4B	C-13		D- 9
2GV-11610-20	B- 5	2JU-14141-90	B-11	2GV-15316-00	C- 2	3JB-17531-20	C- 8	3AA-21578-21	D- 7	2GV-23125-00	D- 8
2GV-11610-40	B- 5	4G0-14142-35-A0	B-11	2H7-15361-00	C- 2	3JB-17531-30	C- 8	2NT-21597-01	C-13		D- 9
2GV-11631-00	B- 5	3UH-14146-00	F- 6	3F9-15362-00	C- 2	3JB-17531-40	C- 8	2NT-21598-00	C-13	2NT-23126-01	D- 8
22U-11633-01	B- 5	214-14147-00	B-12	11H-15383-01	B-14	3JB-17531-50	C- 8	2GV-2160E-00	C-13	5U8-23129-00	D- 8
2GV-11636-00	B- 5	22U-14147-00	B-11	2NT-15411-01	C- 2	1J7-17537-Y0-30	D- 4	3BR-21610-00-PO	C-13		D- 9

NUMERICAL INDEX

PART NO.	GRID NO.	PART NO.	GRID NO.	PART NO.	GRID NO.	PART NO.	GRID NO.	PART NO.	GRID NO.	PART NO.	GRID NO.
2NT-23136-01	D- 8	2GV-24311-00	D-11	2GV-25381-00	E- 2	5HO-26393-00	E- 4	11H-81844-00	E-12	3LR-83364-00	F- 5
2GV-23141-00	D- 8	2GV-24312-00	D-11	156-25398-00	D-14		E- 5	26H-81847-00	E-12	18G-83365-00	E-13
	D- 9	3JB-24314-00	D-12		E- 2	2GV-27211-00-93	E- 8	3AY-81940-00	F- 5	35J-83371-30	F- 6
2GV-23144-00	D- 8	3JB-24316-00	D-10	3JB-2580U-00	D-15	2GV-27311-00-R4	E- 9	25G-81950-01	F- 5	1FK-83507-00	E-14
	D- 9	3JB-24317-00	D-10	3JB-25827-00	D-15	5HO-27315-00	E-10	42X-81960-A1	F- 5	2GV-83509-00	E-14
2AJ-23145-00	D- 8	2GV-24491-00	D-11	3JB-25831-00	D-15	1RM-27410-00-93	E- 8	3JB-81975-00	F- 5	3BT-8351A-00	E-14
	D- 9	3JB-24500-02	D-11	1J3-25834-01	D-15	1NH-27413-00	E- 8	4H7-81980-M0	F- 5	12R-83513-00	E-14
1GU-23151-00	D- 8	4X8-24512-00	D-11	34X-25845-00	D-15		E- 8	1AJ-82103-00	F- 6	123-83516-21	E-15
	D- 8	3AJ-24523-00	D-11	341-25846-00	D-14	4X7-27414-00	E- 8	1VJ-82110-60	F- 5	2GV-83517-00	E-14
1HX-23154-00	D- 8	3AJ-24534-00	D-11	1L9-25847-00	D-14	1RM-27420-00-93	E- 8	2GV-82115-00	F- 5	42X-83517-00	E-14
	D- 9	1FK-24560-00	D-11	2GV-25850-01	E- 6	2NT-27430-01	E- 9	2GV-82116-00	F- 5		E-14
1HX-23156-00	D- 8	1FK-24566-00	D-11	4H7-25850-02	E- 7	1NH-27433-00	E- 9	120-82131-00	F- 5	2GV-83519-00	E-14
	D- 9	4X7-24602-02	D-10	3GM-25852-01	E- 6		E- 9	1AE-82151-00	F- 5	3BT-83530-10	E-14
1GU-23157-00	D- 8	4X7-24612-00	D-10	4H7-25852-00	E- 7	2NT-27437-00	E- 9	36Y-82151-00	F- 5	34L-83550-01	E-14
	D- 8	51X-24705-00	D-13	4K0-25854-00	E- 6		E- 9	3BT-82305-00	F- 6	1AA-83912-00	F- 3
2NT-23164-00	D- 6	3JB-24710-00	D-13	4L0-25854-00	E- 7	2NT-27440-01	E- 9	2GV-82310-21	F- 6	2GV-83912-00	F- 4
2GV-2317E-00	D- 7	3JB-24711-00	D-13	4L0-25862-00	E- 6	2GV-27471-00	E- 9	2GV-82320-20	F- 6	2W1-83922-00	F- 3
2GV-2317F-00	D- 6	3JB-24718-00	D-13		E- 7	2GV-27472-00	E- 9	2GV-82370-00	F- 6		F- 4
3JB-2317F-00	D- 6	18A-24724-00	D-13	4L0-25867-00	E- 6	2GV-27491-00	E- 9	3BT-82509-00	F- 6	3TB-83936-00	D- 6
2GV-2317M-00	D- 7		D-13		E- 7	2GV-28100-00	D-13	2NT-82510-01	F- 5	437-83936-01	F- 3
2GV-23171-00	D- 8	23T-24724-01	D-10	2GV-25872-01	E- 7	4K5-2814E-10	D-13	2GV-82530-03	F- 5		F- 4
	D- 8		D-10	3JB-25872-01	E- 6	3JB-28185-00	D- 2	1L9-82540-00	F- 6		F- 6
1GU-23173-00	D- 8	3JB-24728-00	D-13	2GV-25886-00	D- 9	4K5-28186-00	D-13	1FK-82541-00	F- 6	437-83936-11	D-11
	D- 8	3JB-24750-00	D-13	2GV-25919-00	D-15	2NT-46101-00	D- 4	4FY-82560-00	F- 6		F- 3
2GV-23174-00	D- 6	3JB-24751-00	D-13	34X-25926-00	D-15	22U-46117-00-25	D- 4	3LD-82566-70	F- 5	55R-83963-01	F- 3
3BR-23340-00	D- 9	3JB-24754-00	D-13	34X-25937-00	D-15	22U-46117-00-30	D- 4	3BT-82590-10	F- 5	3JB-83964-00	F- 3
2A6-23408-00	D- 7	3JB-24776-00	D-13	5R2-25937-00	D-15	22U-46117-00-40	D- 4	3LS-82790-00	F- 6	2NU-83972-10	F- 4
156-23411-00	D- 9	3JB-2478F-00	D-13	2GV-26111-10	E- 5	22U-46117-00-50	D- 4	10M-82911-00	F- 4	2YL-83972-00	F- 4
183-23411-00	D- 6	51Y-24796-00	D-13	2NT-26111-10	E- 4	22U-46118-00-12	D- 4	11U-82911-00	F- 3	3BT-83972-00	F- 3
156-23412-00	D- 6	2GV-25104-00	D-14	3JB-26240-00	E- 4	22U-46118-00-14	D- 4	2GV-82917-00	F- 4	2NT-83980-00	F- 5
183-23412-00	D- 6	341-25111-01-35	D-14		E- 5	22U-46118-00-16	D- 4	2NT-82917-00	F- 3	42X-84124-60	E-15
4K0-23415-00	D- 6	146-25115-00	E- 2	3JB-26241-00	E- 4	22U-46118-00-18	D- 5	3LS-83310-00	E-13	2F9-84314-00	E-15
4H7-23441-00-38	D- 6	341-25149-00	D-14		E- 5	22U-46118-00-20	D- 5	1KT-83311-00	E-13	42X-84315-01	E-15
3AL-23442-00-38	D- 6	2GV-25181-00	D-14	3JB-26273-00	E- 4	2H7-46122-00	D- 4		E-13	55R-84321-H0	E-15
42X-23442-00-38	D- 6	1FK-25190-00	D-14		E- 5	22U-46123-00	D- 5	2AE-83312-00	E-13	42X-84330-01	E-15
164-23462-00	D- 9	2GV-25304-00	E- 2	3JB-2628J-00	E- 4	4H7-46125-00	D- 4	42X-83312-00	E-13	20X-84331-00	E-15
3DM-23484-00	D- 7	2GV-25311-00-35	E- 2		E- 5	22U-46136-00	D- 4	42X-83313-00	E-13	1A0-84332-60	E-15
3JB-24110-01-33	D-10	146-25315-00	D-14	1J7-26290-F0	E- 4	22U-46137-00	D- 5		E-13	198-84334-60	E-15
3JB-24135-00	D-10	2GV-25317-00	E- 2		E- 5	22U-46152-00	D- 4	1AA-83318-00	E-13	42X-84338-00	E-15
2GV-24181-00	D-10	1J7-25319-01	D- 5	1J7-26290-G0	E- 4	22U-46153-00	D- 4		E-13	42X-84345-00	E-15
1FK-24182-00	D-10	2GV-25319-00	E- 2		E- 5	2GV-46172-00	D- 5	2EN-83330-00	E-13	34L-84346-00	E-15
	D-10	2NT-25321-00	E- 2	2GV-26311-00	E- 4	4X7-46180-00	D- 5	341-83333-70	E-13	42X-84366-00	E-15
3JB-24182-00	D-10	4H7-2533A-02	E- 2	2NU-26311-00	E- 5	2GV-81410-20	E-11		E-13	2F9-84375-00	E-15
42X-24183-00	D-10	4H7-25351-00	E- 2	3JB-26335-00	E- 4	3BT-81450-00	E-11	41R-83350-71	F- 6	5Y3-84395-00	E-15
2GV-24184-00	D-11	214-25355-00	E- 2	55U-26335-01	E- 5	3BT-81670-00	E-11	42X-83359-00	E-13	2F9-84397-01	E-15
1FK-24186-00	D-10	2GV-25366-00	E- 2	1E6-26342-00	E- 4	3JB-81800-00	E-12		E-13	2YL-84700-E0	F- 2
	D-11	42X-25371-00	E- 3		E- 5	3HE-81826-00	E-12	42X-83363-00	E-13	1RM-84704-00	F- 2
2GV-24191-00	D-11	22U-25377-00	E- 3	2GV-26351-00	E- 8	3KS-81840-00	E-12		E-13	31L-84714-00	F- 2

NUMERICAL INDEX

PART NO.	GRID NO.	PART NO.	GRID NO.	PART NO.	GRID NO.	PART NO.	GRID NO.	PART NO.	GRID NO.	PART NO.	GRID NO.
2GV-84717-00	F- 2	90119-06114	D-13	90185-08097	B-13	90215-16222	C- 5	90460-52264	B-10	90560-17126	D-14
2AE-84721-00	F- 2	90119-06123	C-13	90185-10037	E-10	90215-18178	C-10	90460-58015	B-10	91311-05010	D-10
42X-84723-01	F- 2		C-15	90185-14070	C- 8	90215-22244	C- 5	90462-06119	C- 3	91311-06018	C- 2
2YL-84751-00	F- 2		D-11	90201-044A2	C-14	90249-12008	E- 8	90462-10115	C- 2	91311-06025	B- 2
449-85131-02	C-14	90119-08126	D- 4	90201-05031	E-14	90267-40076	C-14	90462-10118	C- 3		B- 7
90101-06288	E- 8	90123-08046	E- 4	90201-06059	C-13	90269-04003	D- 7	90465-13169	E- 9		B- 8
90101-06291	E- 2		E- 5		C-15	90280-05048	B- 5	90467-10008	B-12		B- 9
90101-06576	B-13	90149-06008	D-11	90201-06067	B-10	90280-07036	C- 5		D-12		B-13
90101-06760	E-13	90149-06153	F- 3		D-13	90338-07043	C-11	90467-10039	B-10		C- 2
	E-13		F- 4	90201-061H3	E-15	90338-08163	D- 6	90467-10135	D-11		C- 2
	D-15	90149-06154	F- 4	90201-065G8	D-11	90338-09161	E- 9	90467-11044	D-11	91311-06030	B- 8
90101-08312	C-11	90149-08067	C- 6	90201-066M2	D-10	90340-14068	C- 2		D-12		C- 2
90105-06069	D-10	90149-08152	B-14	90201-06697	B- 3	90340-32088	C- 2	90467-14015	B- 2	91311-06040	C- 2
90105-06700	C-11	90149-10238	C-11	90201-08087	C- 6	90380-28110	B- 7	90468-12006	D- 6		C- 2
90105-08177	D- 6	90149-10239	B-14	90201-081H4	C-11	90387-06026	F- 2	90480-10334	C-12	91311-06045	B-14
90105-08698	E-11	90151-08022	B-14	90201-081K4	F- 6	90387-062L2	D-11	90480-12320	C-15	91311-06055	B-14
90105-10152	C-11	90157-05050	B-12	90201-08569	D-10	90387-062T3	B-10	90480-13163	D-11		C- 2
90105-10183	C-11	90157-05079	F- 5	90201-08753	D- 3	90387-06387	D-10	90480-14023	D-11		C- 2
90105-10186	E- 2	90157-05084	E-15	90201-09461	B- 2		D-11	90480-14229	C-15	91311-06060	B- 9
90105-10200	B- 7	90159-06016	B-13	90201-100A1	D- 6	90387-06388	D-12		F- 2	91311-06085	B- 4
90105-10217	D- 5	90163-04003	E-14	90201-10100	E- 9	90387-06518	B- 3	90480-15061	F- 2	91311-06095	B- 9
90105-10285	E- 9	90164-03010	E-14	90201-10118	D- 6	90387-072W2	B- 3	90480-16112	F- 2		B-14
90105-10312	D-15	90164-04009	E-14	90201-10118	E- 6	90387-07391	C-15	90480-18411	B- 3	91311-08025	D- 8
90105-10638	D- 6	90170-06010	F- 3		E- 7	90387-087K5	E- 8	90480-19471	B- 3		D- 9
90105-14102	D- 3		F- 4	90201-10131	B- 2		E- 8	90480-22362	C-15	91311-08030	B- 2
90106-10052	F- 3	90170-06128	B- 6		C-11	90387-100E2	C-11	90501-04623	C- 4		D- 6
90109-06577	F- 4	90170-06228	C-10	90201-10437	C-11	90387-107A7	E- 9	90501-06022	C- 9	91311-08060	B-14
	F- 3	90170-16311	C- 5		D- 3	90387-156G8	D- 5	90501-100F8	D-12	91311-08080	B-14
90109-06799	F- 4	90170-20310	C- 5	90201-105H3	C-11	90387-157R0	E- 3	90501-101J4	D-10	91311-08100	B-14
	E- 3	90171-14031	E- 3	90201-107K6	E-11	90387-16547	B-14	90501-10245	E- 8	91316-06016	D- 7
90109-08368	E- 3	90176-06058	E- 8	90201-124E4	C-10		B-14	90501-10312	F- 3	91316-06020	B-10
90109-08406	C-11		E- 8	90201-12575	C-10		B-14		F- 4	91316-08012	C- 4
90109-08718	B- 3	90176-06072	F- 5	90201-12588	C-10	90387-177R1	D-14	90501-12743	E- 9	91401-20015	E- 3
90109-08781	B- 3	90176-10073	D- 3	90201-14218	E- 2	90387-226G7	B- 2		E- 9		E- 8
90109-08782	E- 9	90179-06176	E- 8	90201-144J5	E- 3	90387-256G9	D- 4	90501-15722	D- 5		E- 9
90109-10060	E-10	90179-08148	E- 4	90201-14633	C- 8	90401-10096	E- 6	90501-23738	C- 5		E- 9
90109-10474	B- 3		E- 5	90201-152L1	E- 8		E- 7	90501-60716	C- 8	91401-25015	E- 8
90110-06198	D- 8	90179-08327	B- 5	90201-18262	C- 6	90401-16073	B- 3	90502-09024	D- 7		E- 8
90110-08110	B-14	90179-08410	B-13	90201-244A8	D- 3	90430-06139	C-14	90506-08227	C-10	91401-30030	E- 3
90116-08404	B-14	90179-10279	B- 2	90202-05193	D-11	90430-08155	D- 8	90506-20380	E- 8	91701-06022	E- 8
	D- 4		C-11	90202-06010	C-11		D- 9	90506-29266	E-10	91701-06032	E- 9
90116-10249	B-14	90179-10321	C-11	90208-04029	D- 7	90430-17168	B- 3	90507-20002	E- 2		E- 9
90116-10405	B-14	90179-10395	B- 2	90209-22191	C- 7	90430-24184	B- 2	90508-16577	C- 5	91701-08038	E- 8
	B-14	90179-12421	C-11		C- 7	90445-08248	F- 5	90508-18696	E- 8		E- 8
90116-10406	B-14	90179-18396	C- 8	90209-27192	C- 7	90445-111F3	B-10		E- 8	91810-17016	B-14
	D- 4	90179-25033	D- 6	90214-16026	C- 5	90450-22017	D-10	90508-29519	C-10		C- 3
90116-10428	C-11	90183-04027	B-13	90215-08229	B- 3	90450-25037	D-10	90508-32536	C-10	92016-06012	E- 9
90116-12495	F- 2		C-15	90215-16181	D- 3	90460-12256	B-10	90560-08326	C-13		E- 9

NUMERICAL INDEX

PART NO.	GRID NO.	PART NO.	GRID NO.	PART NO.	GRID NO.	PART NO.	GRID NO.	PART NO.	GRID NO.	PART NO.	GRID NO.
92016-08016	F- 5	92990-08100	E- 3	93306-90602	C- 9	95303-06600	C-14	97021-06025	E-12	98903-08014	C-13
92506-06012	C-14	92990-10100	D- 3	93311-43729	D- 4		E- 8	97026-06030	D-11	99006-10600	C-10
92506-06035	C-15	93101-14089	C- 2	93315-21813	C- 5		F- 2	97026-08030	B-13		C-10
92901-04100	B-11	93101-30084	D- 4	93316-01301	D- 4	95303-06700	C-10	97313-06016	E-15	99009-11400	B- 8
	B-11	93101-35097	C- 8	93317-41510	D- 4	95303-08700	E- 3	97313-08016	D-10	99009-12400	C-10
92901-05100	E- 2	93101-38098	D- 4	93320-32403	D- 3	95303-10700	D- 6	97313-08035	D- 3	99009-15400	E- 8
92901-05600	E- 2	93102-12106	C-10	93399-99926	D- 5	95303-12600	E-13	97701-40012	B-13	99009-25500	C- 2
92901-06200	C- 5	93102-18278	C- 5	93410-22039	D- 5	95306-12800	C-11		C-15	99224-00100	D-10
	E- 8	93102-28022	D-14	93440-12052	B- 2	95311-10600	D- 5	97701-40525	F- 2	99225-00100	D-10
92901-06600	B- 3	93102-65277	D- 5	93440-19112	D- 5	95311-12700	D- 6	97706-60514	C-12	99234-00080	C-13
	B- 7	93105-45017	D-14	93440-20088	D- 5	95316-08700	B-13	98501-04006	D- 8	99235-00080	C-13
	B-13	93210-03119	B-12	93440-25084	C- 7	95601-06100	F- 3		D- 9	99510-17016	B- 2
	B-15	93210-09525	C- 5		C- 7		F- 4	98501-05010	B-12	99530-10014	C- 2
92901-08200	E-12	93210-10096	B- 8	93440-30077	C- 7	95611-08630	B- 2	98501-05012	B-12	99530-10020	C- 2
92901-08600	C-13	93210-11368	F- 3	93450-19052	B- 5	95611-10680	B-14		E- 2	99530-14016	B-14
	E- 3		F- 4	93450-32116	D- 8	95616-06100	F- 3	98501-05016	B-11		B-14
92901-10100	D- 5	93210-14369	C- 2		D- 9		F- 4	98501-05035	F- 4		
92901-12100	D- 6	93210-15151	B- 8	93501-04011	D- 6	95701-06500	D-13	98501-06010	C- 3		
92901-12200	D- 6	93210-15566	C- 3		E- 9		E-13		F- 5		
92902-04100	B-11	93210-18322	B-14		E- 9		E-13	98501-06012	B-15		
92906-05100	F- 6		B-14	93515-32029	C- 6		F- 5	98501-06020	E-11		
	F- 6		B-14	93604-16092	C- 9	95701-08500	B- 2		F- 6		
92906-05600	F- 6	93210-24709	D- 8	93604-20156	C- 9	95701-10500	E- 9	98501-06025	E-11		
	F- 6		D- 9	93605-10108	B- 7	95801-06012	F- 5	98502-06016	F- 5		
92906-06100	C-15	93210-27778	C- 2	93615-12088	C- 4	95801-06016	B-13	98503-03008	D-11		
	D-11	93210-29196	F- 6	94114-15601	E- 2	95801-08012	D- 3	98506-04018	B-11		
	E- 6	93210-32172	C- 2	94114-15602	E- 2	95806-06040	C-15	98506-05016	D-11		
	E- 7	93210-36549	B-10	94130-197N0	D-14	95811-06016	F- 2		F- 6		
	F- 3	93210-60426	D- 4	94130-197N1	D-14	95811-08030	C- 8		F- 6		
	F- 4	93210-62446	B- 2	94214-15223	E- 2	95811-10016	E- 9	98506-05035	F- 3		
92906-06600	B-13	93210-64297	B- 9	94214-15225	E- 2	95816-06012	C-12	98506-05040	F- 3		
	C-13	93210-71360	C- 8	94227-19177	D-14	95816-06016	D-11		F- 4		
	C-14		C-13	94325-19115	D-14	95816-06025	D-12	98506-05045	F- 3		
	D- 2	93210-74316	C- 2	94330-15134	E- 2	95816-08012	C-13		F- 4		
92906-08600	B-13	93210-81411	B- 4	94335-19026	D-14	95816-08016	B-13	98506-06014	C-13		
92906-08700	B-13	93210-89568	B- 2	94418-19443	D-14	95821-12035	D- 9	98511-04012	B-11		
92990-03200	D-13	93211-00612	B- 2	94430-15477	E- 2	95826-06010	C-13		F- 3		
92990-06100	D-13	93211-39569	D- 5	94590-27118	B- 7		D- 9	98511-04025	E-14		
	E-11	93306-00401	C- 7	94701-00218	B- 3		F- 6	98511-06160	B-10		
	E-11	93306-00428	C- 7	94701-00220	B- 3	97001-06025	C-15	98580-04010	B-11		
	E-15	93306-00435	C- 8	95021-08040	E-15	97003-06014	D-13	98580-06012	B-12		
	F- 6	93306-20711	C- 8	95023-06008	D- 7	97011-06020	C-10	98580-06020	B-13		
92990-06200	C-14	93306-30203	E- 2	95023-06020	D- 6	97011-06025	F- 3	98701-05012	F- 6		
	F- 2	93306-30209	E- 2	95023-08012	C-13		F- 4	98701-05016	C- 9		
92990-06600	F- 5	93306-30309	D-14	95026-06016	C-11	97016-06025	E- 6	98701-05035	C- 9		
	F- 5		D-14	95302-12600	E-13		E- 7	98701-06010	B-12		
	F- 6	93306-30525	C- 7	95303-05600	E-14	97021-06016	B- 3	98706-04012	E- 6		
92990-08100	D- 3	93306-30539	D- 4	95303-06600	C- 5		B- 7		E- 7		

INDEX

(INDIVIDUAL SPEC.)

NUMERICAL INDEX

PART NO.	GRID NO.	PART NO.	GRID NO.	PART NO.	GRID NO.	PART NO.	GRID NO.	PART NO.	GRID NO.
3BT-21110-00-33	F-12	2F9-84397-01	F-14						
3JB-21610-00-PO	F- 8	3Y6-85130-02	F- 8						
3JB-21610-00-R0	F- 8	90157-05084	F- 9						
3JB-21610-00-4B	F- 8		F-14						
3JB-21641-00	F- 8	90164-03010	F-13						
134-23484-10	F-12	90164-04009	F-13						
1FK-83507-00	F-13	90201-05031	F-13						
2GV-83509-00	F-13	90201-061H3	F- 9						
2JV-8351A-F0	F-10		F-14						
	F-13	90267-48104	F- 8						
12R-83513-00	F-13	90480-01502	F-10						
2GV-83517-00	F-13	90480-16501	F-10						
42X-83517-00	F-13	92990-06100	F- 9						
	F-13		F-14						
2GV-83519-00	F-13	95021-08040	F- 9						
3BT-83530-10	F-13		F-14						
34L-83550-01	F-13	95303-05600	F-13						
42X-84124-60	F- 9	95306-05800	F- 8						
	F-14	97313-06016	F- 9						
2F9-84314-00	F-14		F-14						
	F- 9	98511-04025	F-13						
42X-84315-01	F- 9								
	F-14								
2AE-84320-60	F- 9								
	F-14								
42X-84330-01	F- 9								
	F-14								
20X-84331-00	F- 9								
	F-14								
1A0-84332-60	F- 9								
	F-14								
198-84334-60	F- 9								
	F-14								
42X-84338-00	F- 9								
	F-14								
42X-84345-00	F- 9								
	F-14								
34L-84346-00	F- 9								
	F-14								
4E2-84347-00	F- 9								
	F-14								
42X-84366-00	F- 9								
	F-14								
2F9-84375-00	F- 9								
	F-14								
5Y3-84395-00	F- 9								
	F-14								
2F9-84397-01	F- 9								

*COPYRIGHT : All rights reserved. No part of this publication
may be reproduced without permission.*

YAMAHA

YAMAHA MOTOR CO., LTD.
2500 SHINGAI IWA^{TA} SHIZUOKA JAPAN
PARTS OPERATIONS

Printed in Japan
First edition Oct., 1992

16